

ECOPURE®

Water Solved.®

Model ECOP30

How to install, operate
and maintain your
Reverse Osmosis
Drinking Water System

PRODUCT REGISTRATION AND WARRANTY EXTENSION

Please register your product on
www.ecopure.com

See warranty page for
extended warranty details.



If you have any questions or concerns when
installing, operating or maintaining your reverse
osmosis system, call our toll free number:

1-800-693-1138

or visit www.ecopure.com

When you call, please be prepared to provide the
model, date code and serial number of your product,
found on the rating decal, located inside the cover.

System tested and certified by NSF International
against NSF/ANSI Standard 42 for the reduction
of chlorine taste and odor, and Standard 58
for the reduction of arsenic, barium, cadmium,
chromium (hexavalent), chromium (trivalent),
copper, cysts, lead, radium 226/228, selenium,
turbidity and TDS. See performance data on
pages 27 & 28 for details. System tested and
certified to CSA B483.1 and NSF/ANSI/CAN 372



System certified by IAPMO R&T against
NSF/ANSI Standard 58 for the reduction of
nitrate and nitrite.

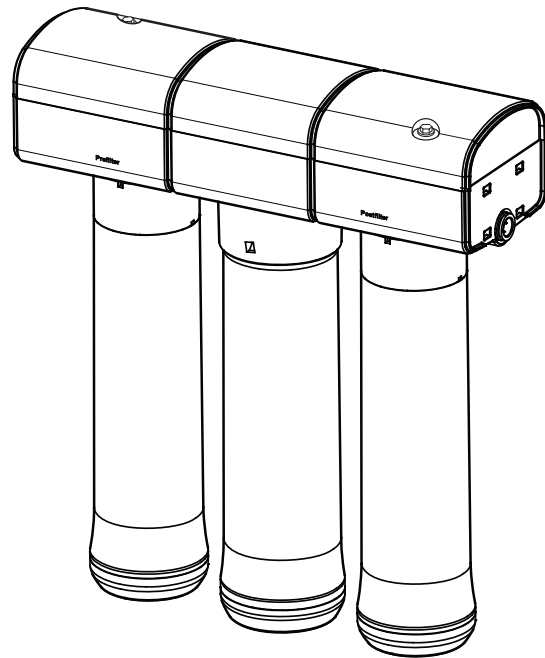
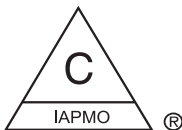

Installation and Operation Manual

Manufactured and warranted by
Water Channel Partners
1890 Woodlane Drive
Woodbury, MN 55125

7400023 (Rev. B 7/1/24)

TABLE OF CONTENTS

	<u>Page</u>
Specifications & Dimensions	3
Unpack and Check Shipment	4
Plan Your Installation	5-6
Overview & Site Preparation	7
Installation Instructions	8-17
Step A - Install Supply Water Fitting	8
Step B - Install Reverse Osmosis Drain	9-10
Step C - Install Reverse Osmosis Filter Assembly	11
Step D - Install Storage Tank	11
Step E - Install Reverse Osmosis Faucet	12-13
Step F - Connect Tubes	14-15
Step G - Sanitize, Pressure Test & Purge System	16-17
How Your Reverse Osmosis System Works	18-19
Maintenance	20-21
Troubleshooting	22-23
Exploded View & Parts List	24-25
Warranty	26
Performance Data	27-29

Specifications & Dimensions

Supply water pressure limits	40-100 psi (280-689 kPa)
Supply water temperature limits	40-100 °F (4-38 °C)
Maximum total dissolved solids (TDS)	2000 ppm
Maximum water hardness @ 6.9 pH	10 gpg
Maximum iron, manganese, hydrogen sulfide	0
Chlorine in water supply (max. ppm)	2.0
Supply water pH limits (pH)	4-10
Product (quality) water, 24 hours ¹	14.76 gal. (55.9 liters)
Percent rejection of TDS, minimum (new membrane) ¹	86.5
Automatic shutoff control	yes
Efficiency ²	10.6 %
Recovery ³	21.2 %

This system conforms to NSF/ANSI 58 for the specific performance claims as verified and substantiated by test data.

¹ @ Feed water supply at 50 psi, 77°F, and 750 TDS --- Quality water production, amount of waste water and percent rejection all vary with changes in pressure, temperature and total dissolved solids.

² Efficiency rating means the percentage of the influent water to the system that is available to the user as reverse osmosis treated water under operating conditions that approximate typical daily usage.

³ Recovery rating means the percentage of the influent water to the membrane portion of the system that is available to the user as reverse osmosis treated water when the system is operated without a storage tank or when the storage tank is bypassed.

Non-potable Water Sources: Do not attempt to use this product to make safe drinking water from non-potable water sources. Do not use the system on microbiologically unsafe water, or water of unknown quality without an adequate disinfection before or after the system. This system is certified for cyst reduction and may be used on disinfected water that may contain filterable cysts.

Arsenic Reduction: This system shall only be used for arsenic reduction on chlorinated water supplies containing detectable residual free chlorine at the system inlet. Water systems using an inline chlorinator should provide a one minute chlorine contact time before the reverse osmosis system.

Nitrate/Nitrite Test Kit: This system is supplied with a nitrate/nitrite test kit. Product water should be monitored periodically according to the instructions provided with the test kit.

Total Dissolved Solids Test Kits: TDS test kits are available by calling IAS Labs at 1-602-273-7248, or check the water testing section of your local phone directory.

Installations In The Commonwealth Of Massachusetts: The Commonwealth of Massachusetts requires installation be performed by a licensed plumber and do not permit the use of saddle valves. Plumbing code 248--CMR of the Commonwealth of Massachusetts must be followed in these cases.

Product Water Testing: The Reverse Osmosis System contains a replaceable treatment component critical for the effective reduction of total dissolved solids. Product water should be tested periodically to verify that the system is performing properly.

Replacement of the reverse osmosis component: This reverse osmosis system contains a replaceable component critical to the efficiency of the system. Replacement of the reverse osmosis component should be with one of identical specifications, as defined by the manufacturer, to assure the same efficiency and contaminant performance.

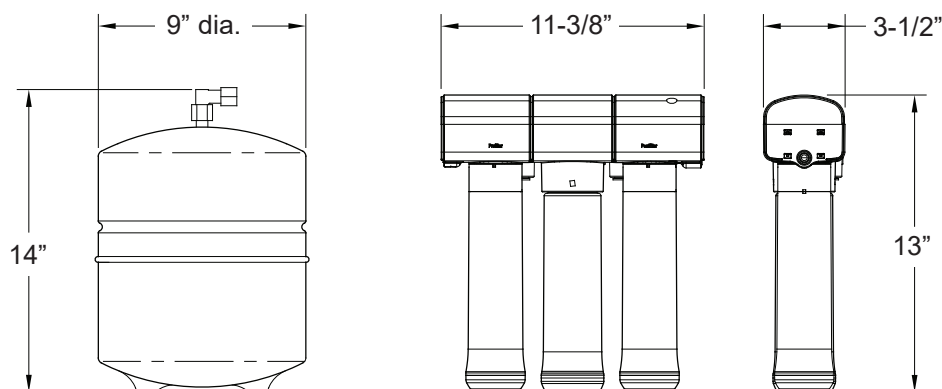

FIG. 1

Unpack and Check Your Carton

INSPECT SHIPMENT

Your Reverse Osmosis Drinking Water System is shipped complete in one carton. Remove all items from your shipping carton.

Check all items against the packing list below. Note any items lost or damaged in shipment. Note any damage to the shipping carton. Refer to the exploded view and parts list in the back of the manual for the part names and numbers of missing or damaged items.

If your new ECOP30 has missing or damaged items, please call toll free 1-800-693-1138 for free and swift replacement of missing or damaged items.







If problems exist, refer to the website or the toll free number listed throughout this manual.

Keep the small parts in the parts bag until you are ready to install them.

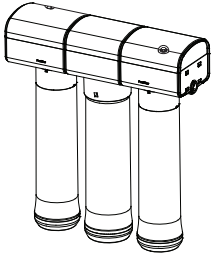
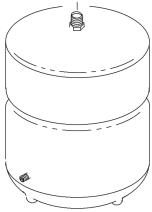
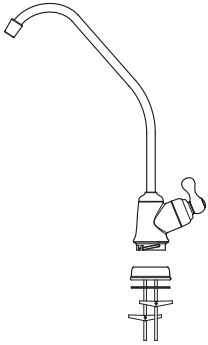
NOTE: Codes in the state of Massachusetts require installation by a licensed plumber and do not permit the use of saddle valves.

If you live in the state of Massachusetts, review plumbing code 248-CMR of the Commonwealth of Massachusetts before proceeding with the installation.

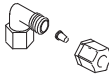
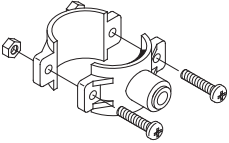
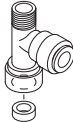
Packing List

 <p>Reverse Osmosis Assembly with Red & Yellow Tubes attached</p>	 <p>Product Water Storage Tank</p>	 <p>Reverse Osmosis Faucet</p>	Parts Bag		
 <p>Tubes (Green, Black & Blue)</p>			 <p>Hanger Brackets</p>	 <p>Eye Dropper</p>	 <p>Tank Connector</p>
			 <p>Drain Adaptor</p>	 <p>Water Supply Fitting</p>	 <p>Nitrate / Nitrite Test Kit</p>
FIG. 2					

Plan Your Installation

PLAN YOUR INSTALLATION

Read through the entire manual before beginning your installation. Follow all steps exactly. Reading this manual will also help you get all the benefits from your system.

Your Reverse Osmosis Drinking Water System can be installed under a sink or in a remote location. Typical remote sites are a laundry room or utility room. Review the location options below and determine where you are going to install your system.

NOTE: For best system performance, the feed water to the system should be softened or have hardness less than 10 grains per gallon, with no iron.

UNDER THE SINK LOCATION

The Reverse Osmosis Filter Assembly and storage tank may be installed in a kitchen or bathroom sink cabinet. See Fig. 4.

A suitable drain point is needed for drain water from the Reverse Osmosis system.

REMOTE INTERIOR LOCATION

The Reverse Osmosis Filter Assembly and storage tank may also be installed in a remote interior location away from the Reverse Osmosis Faucet. You will need a nearby water source and drain point.

See Fig. 5.

CHECK SPACE REQUIREMENTS

Check size and position of items for proper installation into location chosen.

TOOLS NEEDED

Review the tools needed list. See Fig. 3. Gather needed tools before proceeding with the installation. Read and follow the instructions provided with any tools listed here.

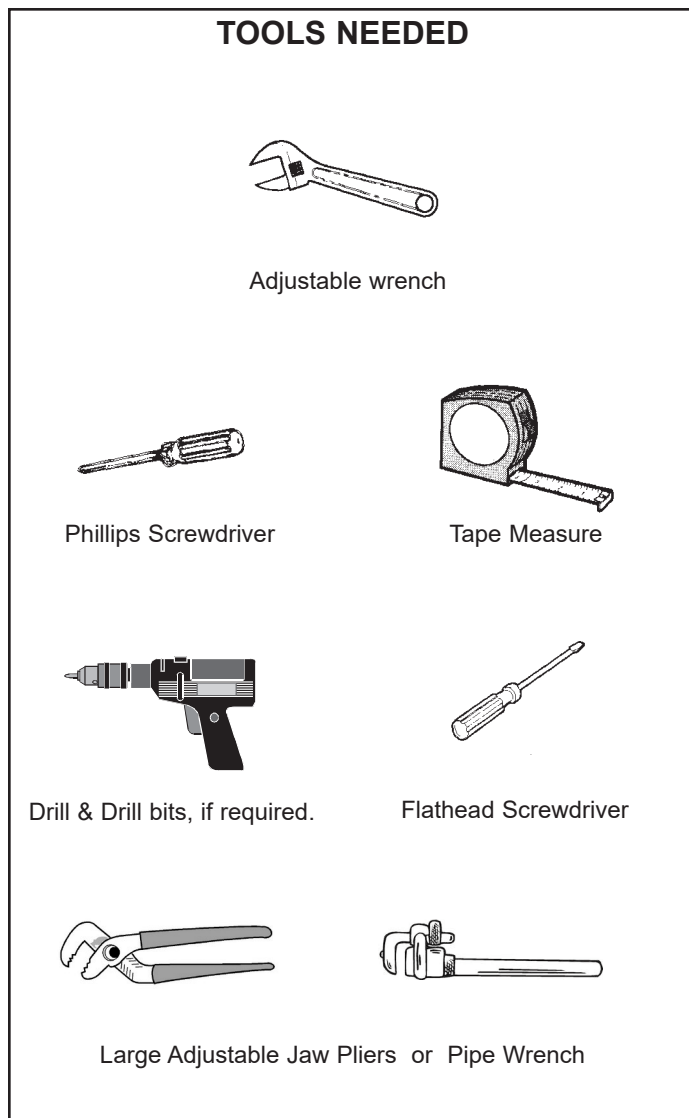

FIG. 3

Questions? Call Toll Free 1-800-693-1138 or visit **www.ecopure.com**

When you call, please be prepared to provide the model, date code and serial number, found on the rating decal, located inside the cover.

Plan Your Installation

All install parts included in package.

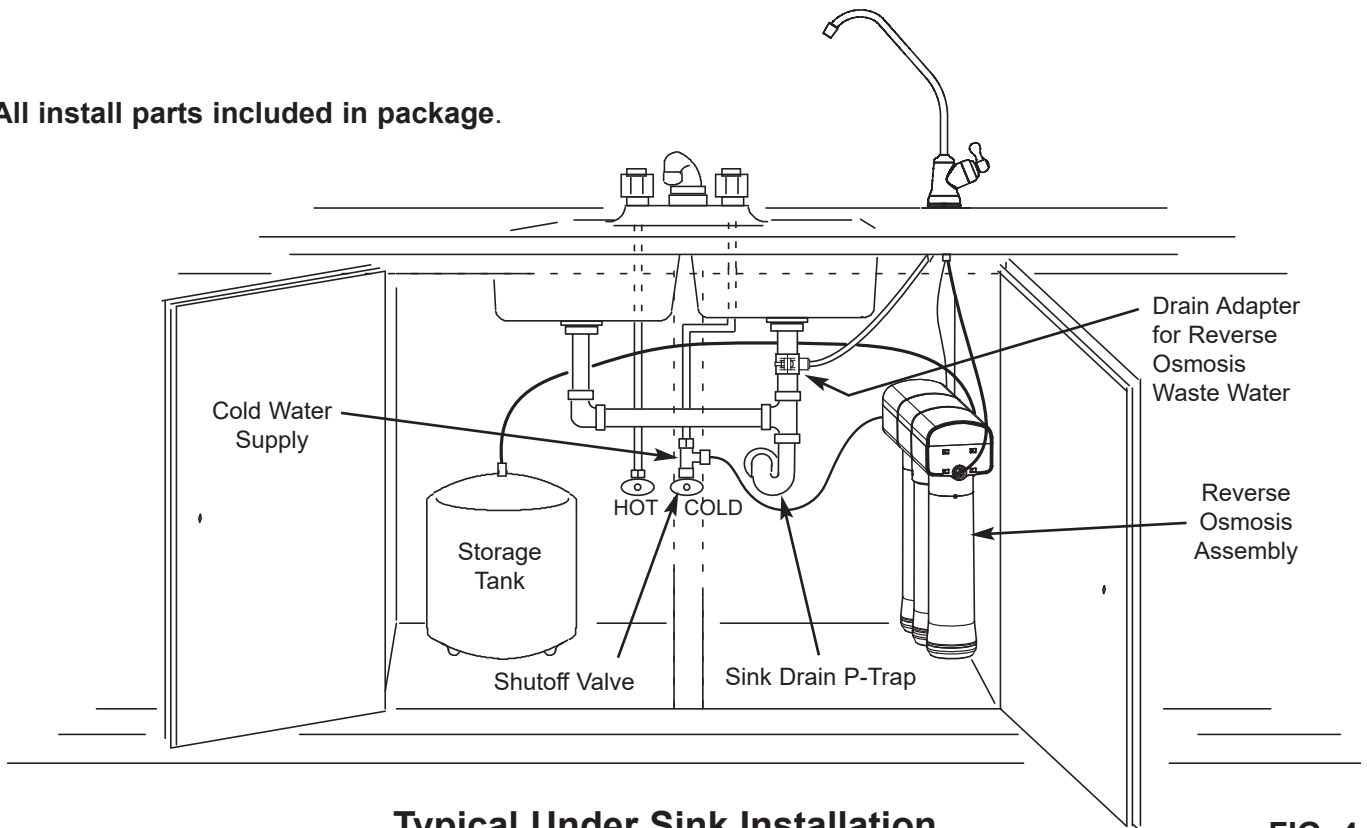

Typical Under Sink Installation

FIG. 4

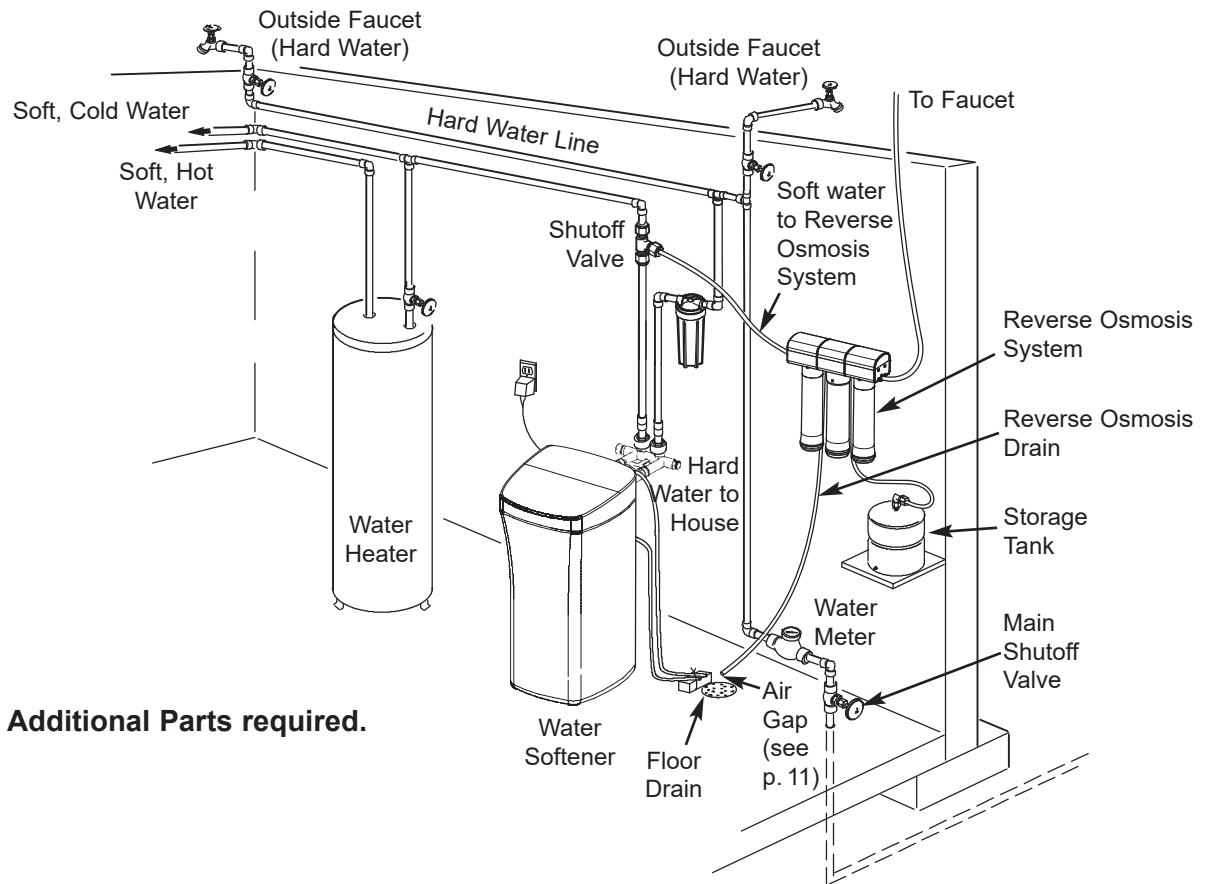

Additional Parts required.

Typical Remote Installation

FIG. 5

Overview and Site Preparation

OVERVIEW

Read through the entire manual before beginning your installation.

There are seven steps to installing your Drinking Water system. They are as follows:

- STEP A** - Install Cold Water Supply fitting
- STEP B** - Install Drain Adapter
- STEP C** - Install Reverse Osmosis Assembly
- STEP D** - Install Storage Tank
- STEP E** - Install Reverse Osmosis Faucet
- STEP F** - Connect Tubing
- STEP G** - Sanitize, Pressure Test, Purge System

These steps are explained in detail over the next few pages. Follow all steps. Reading this manual will also help you receive and use all the benefits your Reverse Osmosis system can give you.

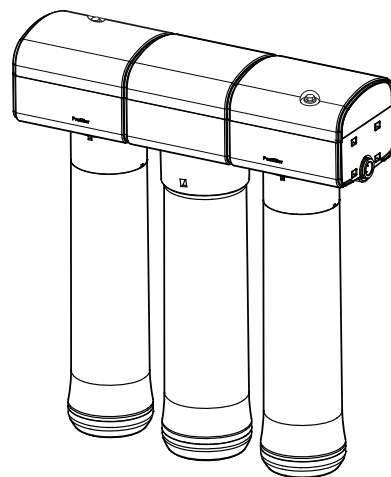

FIG. 6

PREPARE SITE FOR INSTALLATION

1. Before starting, close the hot and cold water shutoff valves (See Figure 7).
2. Temporarily place tank and filter assembly into planned location. Check position of items and space required for proper installation. Ensure tubes may be routed without kinking.
3. Remove tank and filter from planned location and set aside.

NOTE: You must check and comply with all local plumbing codes.

NOTE: Codes in the state of Massachusetts require installation by a licensed plumber and do not permit the use of saddle valves.

If you live in the state of Massachusetts, review plumbing code 248-CMR of the Commonwealth of Massachusetts before proceeding with the installation.

NOTE: For best system performance, the feed water to the system should be softened or have hardness less than 10 grains per gallon, with no iron.

Questions? Call Toll Free 1-800-693-1138 or visit www.ecopure.com

When you call, please be prepared to provide the model, date code and serial number, found on the rating decal, located inside the cover.

Step A - Install Supply Water Fitting

Check and comply with local plumbing codes as you plan, then install a cold feed (supply) water fitting. Refer to the Specifications page for supply water requirements. The fitting must provide a leak-tight connection to the RO 1/4" tubing. A typical connection using the included water supply fitting is shown in Figure 7.

NOTE: Local code may dictate which type of water fitting is used. Consult a plumber if you are not familiar with local codes or plumbing procedures.

NOTE: Codes in the state of Massachusetts require installation by a licensed plumber and do not permit the use of saddle valves.

If you live in the state of Massachusetts, review plumbing code 248-CMR of the Commonwealth of Massachusetts before proceeding with the installation.

INSTALL COLD WATER SUPPLY FITTING

(Included)

This fitting will be installed on the cold water pipe. The fitting must provide a leak-tight connection to the Reverse Osmosis 1/4" tubing. Locate the cold water line in the sink cabinet. It is recommended, but not required, that the cold water line be soft water.

Complete the following steps to install the water supply fitting.

1. Close the water shutoff valve (angle stop valve) that the water supply fitting will be installed on, and open faucet(s) to relieve pressure.
2. Disconnect the existing cold water line from the water shutoff valve.
3. Make sure that the water supply fitting's gasket is inside the female threaded portion of the fitting.
4. Install the water supply fitting onto the cold water shutoff valve, where the existing cold water line was removed, and hand tighten. Be careful not to cross thread or over-tighten.
5. Connect the existing cold water line to the male threaded portion of the water supply fitting and hand tighten. Be careful not to cross thread or overtighten.

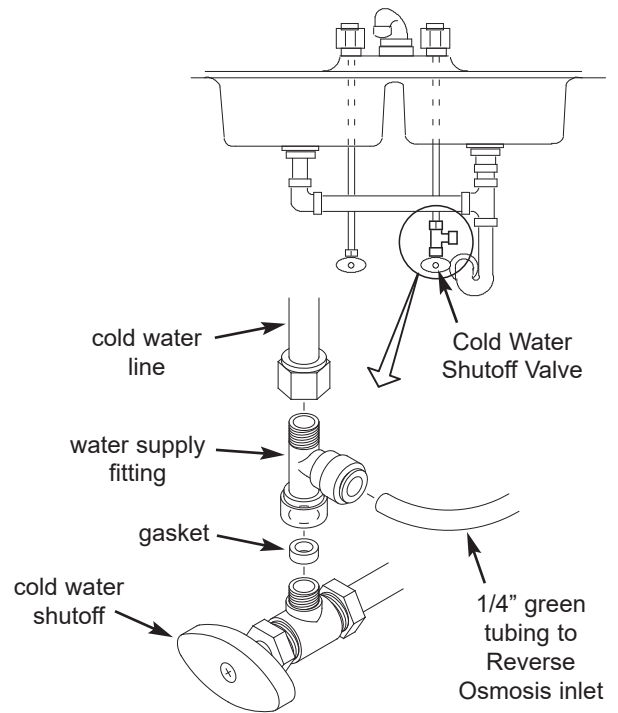

Cold Water Supply Connection
(included in package)

FIG. 7

Step B - Install RO Drain Under Sink

INTRODUCTION

A suitable drain point is needed for the drain water from the Reverse Osmosis filter. You have two options:

- **Install the Drain Adaptor included with your unit**
As shown in Figures 8-10, the drain adaptor is installed onto your sink's drain pipe above the P-trap. This is normally used for under sink installations.
- **Use another existing drain in your home**
As shown in Figures 11 and 12, the drain tube from the RO filter runs directly to an open drain. This is often used for remote location installations.

NOTE: An incorrectly connected drain point can cause water to leak from the faucet's air gap.

NOTE: Local code may restrict the type of drain installation to use. Either drain installation type, if permitted by code, may be used in under sink or remote location installations. Consult a plumber if you are not familiar with plumbing procedures.

INSTALL DRAIN ADAPTOR

(Under sink Installation)

The drain adaptor included with your RO system is designed to fit around a standard 1-1/2" O.D. drain pipe. In the following procedure, you will install the drain adaptor above (upstream of) the P-trap. See Fig. 8 & 10. Be sure to comply with local plumbing codes.

NOTE: Before starting this procedure, inspect the drain pipe under the sink for corrosion, and replace if necessary, before continuing with installation.

1. Test fit the two halves of the drain adaptor onto the sink drain pipe, about 6 inches above the P-trap (See Fig. 9). Make sure that the Q.C. fitting is toward the direction of the RO faucet (See Fig. 10).
NOTE: Locate so that the drain tubing from the Reverse Osmosis faucet will run straight to the adaptor, with no dips, loops, or kinks.
2. Using the hole through the drain fitting as a guide, mark the pipe where a 3/8" hole will be drilled (See Fig. 9), and remove the drain adaptor from the pipe.
NOTE: Do not drill through the drain adaptor's Q.C. fitting, as this could damage the o-ring.
3. Drill a 3/8" dia. hole in the pipe and remove flash.
4. Clean the sink tailpiece to assure a leak-tight fit.
5. Place the halves of the drain fitting back onto the sink drain pipe. Use a pencil or similar pointed object to align the Q.C. fitting so that it is centered on the hole you drilled.
6. Assemble the nuts and screws, as shown in Figure 9, and tighten both sides equally to secure the drain adaptor halves onto the pipe. Do not overtighten.
7. Do not connect black tubing to the Q.C. fitting at this time. It is done after the RO faucet is installed.

Under the Sink Installation

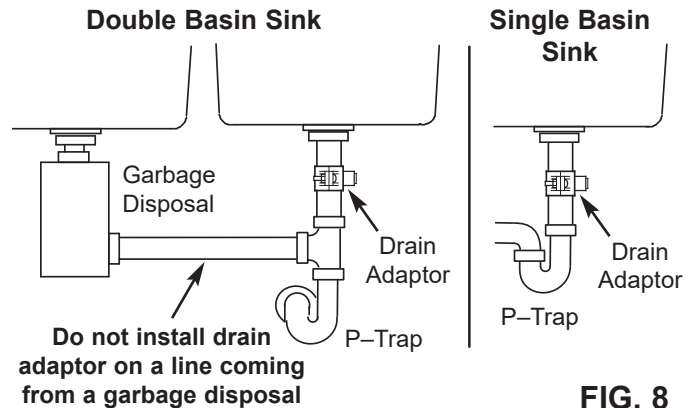

FIG. 8

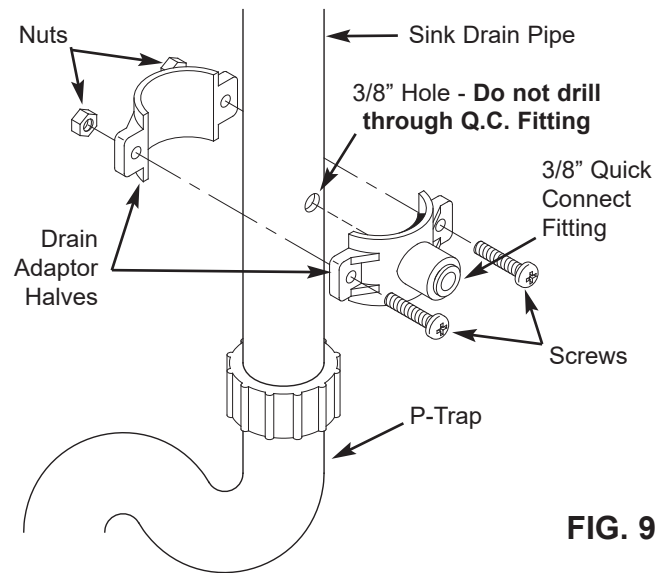
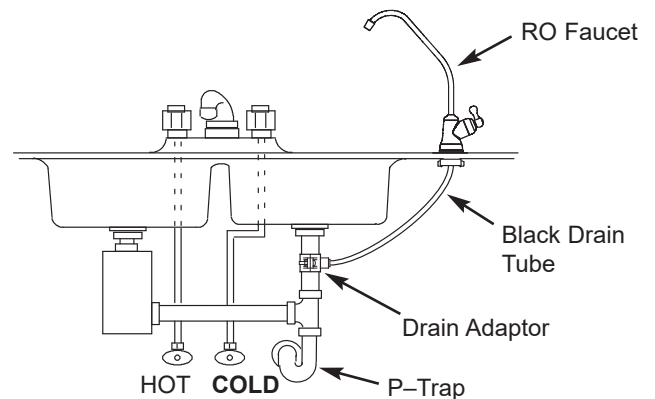

FIG. 9



IMPORTANT: Do not install drain adaptor below the P-Trap. Locate drain adaptor so that when the black drain tube from the Reverse Osmosis Faucet is installed it will run straight to the adaptor, with no dips, loops, or kinks.

FIG. 10

Step B - Install RO Drain In Remote Location

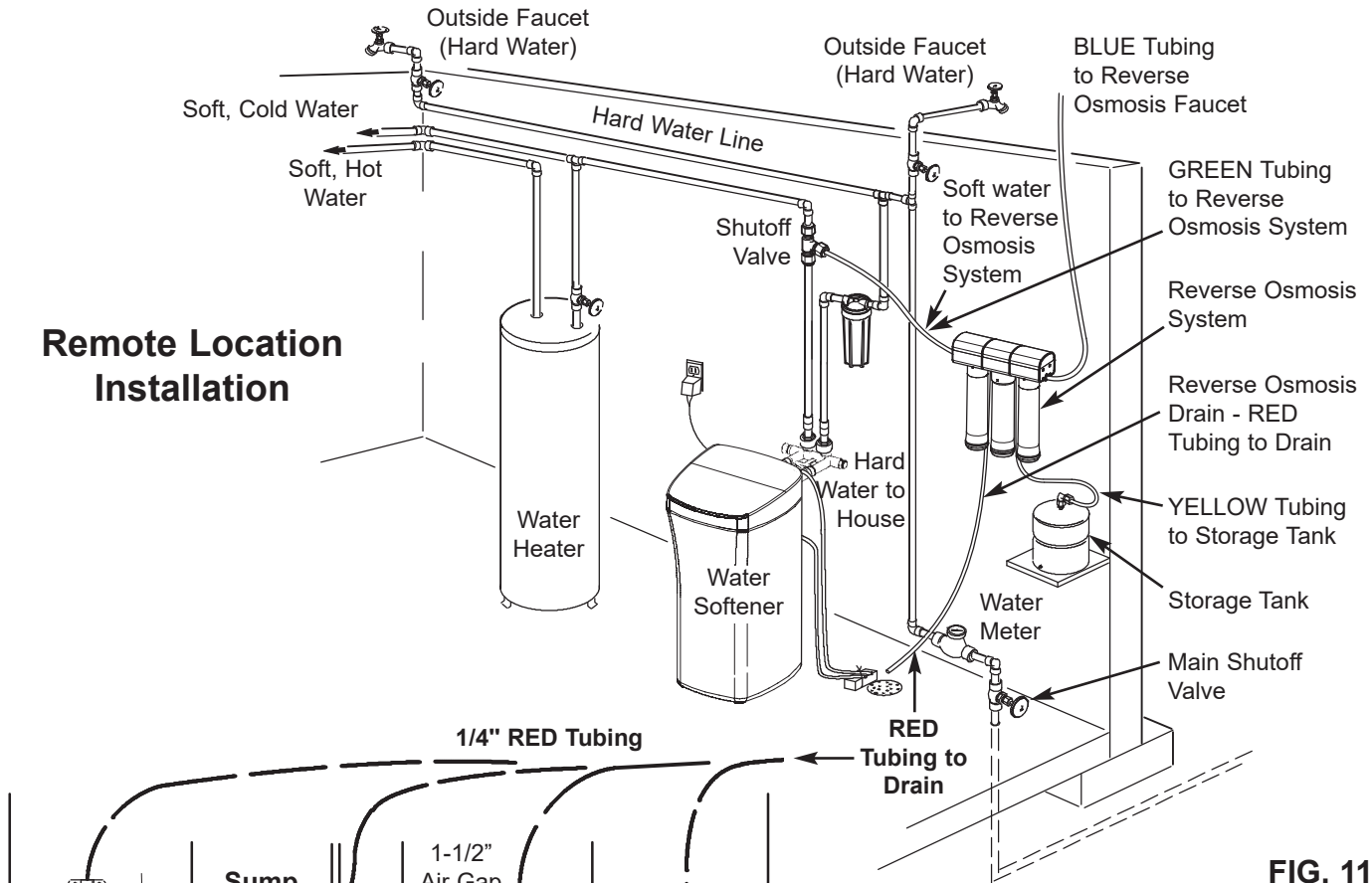

FIG. 11

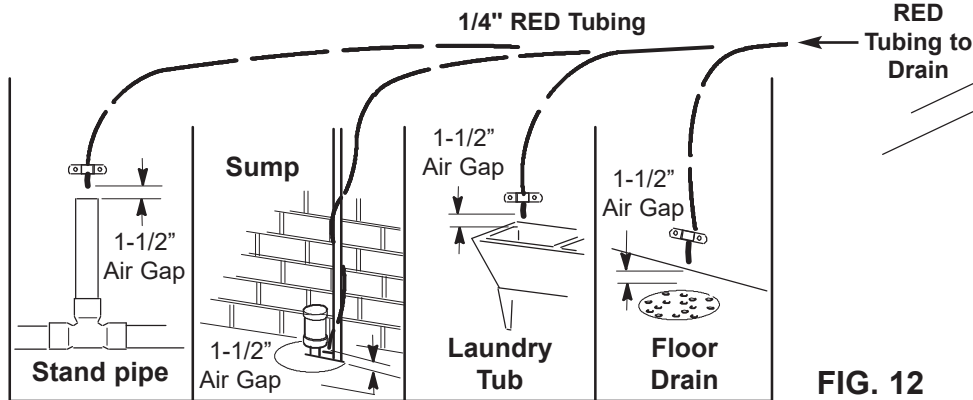

FIG. 12

INSTALL A REMOTE DRAIN POINT AND AIR GAP (Remote Location)

Route the drain tubing to an existing drain in the house. A floor drain, laundry tub, standpipe, sump, etc. are suitable drain points. See Fig. 12. This type of drain is the preferred over the p-trap drain adapter.

Always be sure to provide a 1-1/2" air gap between the end of the hose and the drain point. This will prevent water from backing up into the system.

NOTE: Check your local plumbing codes.

To install a remote drain point, complete the following steps:

1. Locate the 1/4" red tubing on the Reverse Osmosis filter assembly. See Fig. 11.
2. Determine if this length is long enough to reach the drain point. Longer lengths of tubing (see parts list in back of manual) may be needed.
3. If longer tubing is required, disconnect the 1/4" red tubing and replace with an adequate length of tubing to reach the drain point. Refer to Step F later in the manual on how to disconnect and connect tubing. **NOTE: A flow control insert is located inside the elbow fitting that the drain tube connects to. Refer to Fig. 29. Leave this fitting in place.**
4. Route the tubing to the drain point and secure at the end with a bracket (not included). See Fig. 12. Provide a 1-1/2" air gap between the end of the tube and the drain. See Fig. 12.

Step C: Install RO Filter Assembly

INSTALL REVERSE OSMOSIS FILTER ASSEMBLY

The Reverse Osmosis Filter Assembly is mounted on hanger washers.

See Fig 13. The hanger washers allow you to lift the filter assembly from the washers without any hardware removal. When planning your installation, you need to leave room for changing filters.

Complete the following steps to install your Reverse Osmosis Filter Assembly:

1. Remove the cover.
2. Locate mounting slots on back inside of the assembly. See Fig 13.
3. Hold the assembly up to the wall surface and mark locations for the hanger washers. See Fig 13. Mount the unit high enough to allow room to change filters without taking the unit off of the wall.
4. Fasten the hanger washers to the wall using the screws provided.
5. Hang assembly on washers.
6. Replace cover.

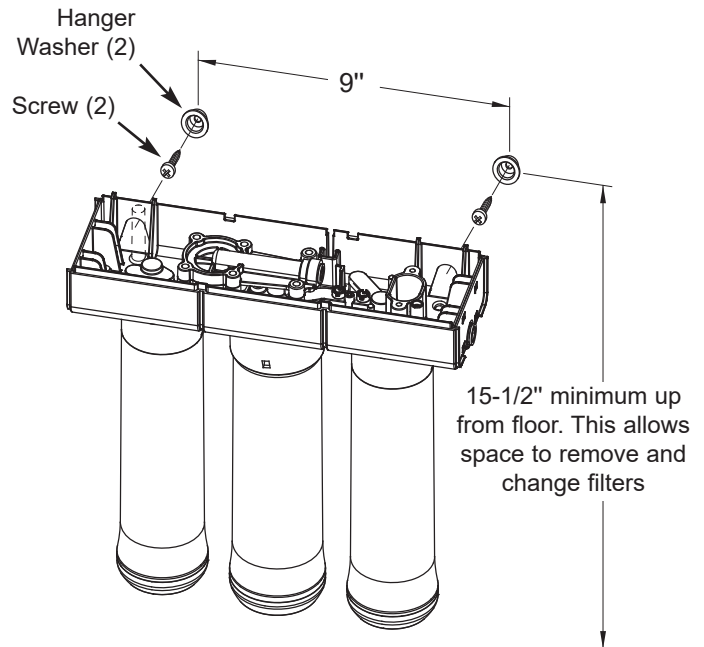

FIG. 13

Step D - Install Storage Tank

The fitting on the supply tank may need to be tightened 7-8 full turns to get a good seal.

Do not overtighten.

INSTALL STORAGE TANK

1. Apply thread sealing tape (2 wraps clockwise) to the threads on the nipple at the top of the tank. See Fig 14.
2. Locate the tubing connector. See Fig. 14. Tighten the tubing connector onto the tank nipple 7-8 full turns, being careful not to cross thread or overtighten.
3. Do not connect the tube at this time. This will occur later in the assembly.
4. Place the storage tank next to the Reverse Osmosis Assembly. The tank can be placed upright or on its side.

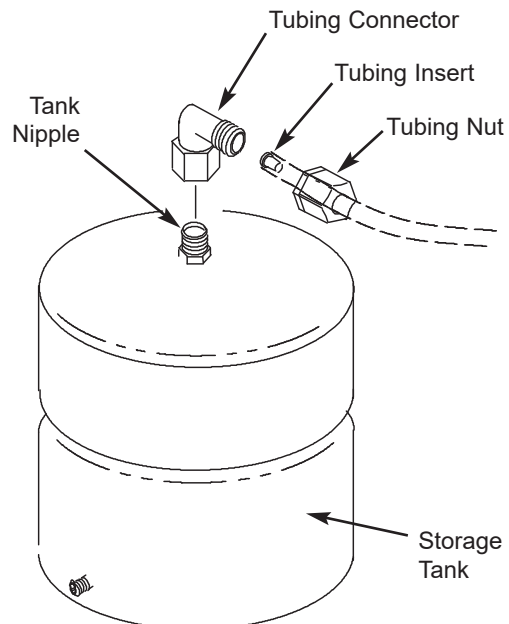

FIG. 14

Step E - Install RO Faucet

SELECT LOCATION OF REVERSE OSMOSIS FAUCET MOUNTING HOLE

You will need to select the location of the Reverse Osmosis Faucet. You have three options to choose from:

- Use the existing sink top hole for the spray hose or soap dispenser (Must be 1-1/4" in diameter)
 - Drill a new hole in the sink
 - Drill a new hole in the countertop next to the sink
1. Determine where you are going to install your Reverse Osmosis Faucet.
 2. Check to ensure the Reverse Osmosis faucet will mount flat against the mounting surface.
 3. Visually review the routing of the tubes from the Reverse Osmosis filter assembly to the faucet. Check to ensure there is adequate tube routing space between the faucet and filter assembly.
 4. If drilling is needed, drill a 1-1/4" diameter hole in the mounting surface.

IMPORTANT: Drilling holes into countertops and sinks should only be performed by an installer who is qualified for drilling such materials. Drilling of surfaces made of stone or solid surface materials such as granite, marble, Corian™ or other plastic resin products or sinks made of porcelain or stainless steel may cause permanent, irreparable damage to the sink or countertop surface.

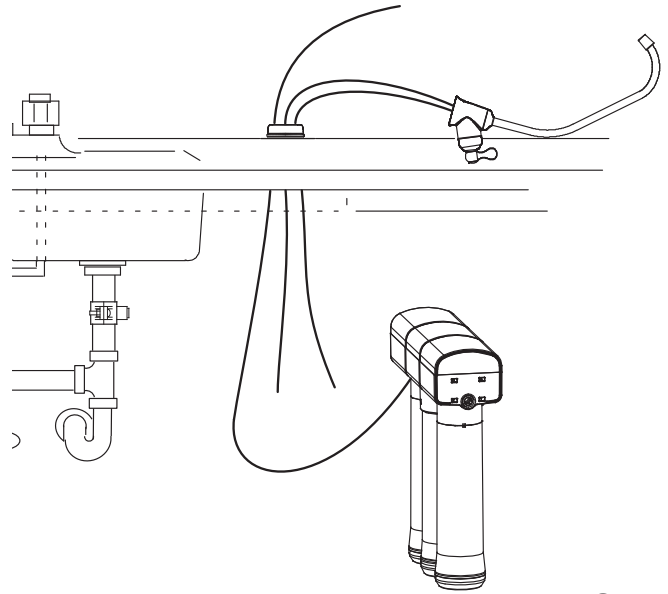

FIG. 15

Questions? Call Toll Free 1-800-693-1138 or visit www.ecopure.com

When you call, please be prepared to provide the model, date code and serial number, found on the rating decal, located inside the cover.

Step E - Install RO Faucet (cont.)

INSTALL REVERSE OSMOSIS FAUCET

1. Locate and organize your RO faucet install parts. Refer to Fig. 16.
2. Mount faucet base to sink hole until the faucet base is flat against the sink surface. The rubber gasket should be between the sink surface and the faucet base.
3. Tighten the toggle bolts until the base is firmly mounted to the sink surface. Do not overtighten.
4. Feed a length of 3/8" blue tubing up through the hole and insert end into the push-in fitting on the bottom of the faucet. See Figure 17. Push tubing through the collet and all the way into the fitting. Full engagement is 3/4" length of tube into the fitting. Pull on the tube to be sure it's held firmly in the fitting. The other end of this tubing will be connected to the RO system, as shown on page 15.

NOTE: If you routed the red drain tubing directly to a remote drain point (see page 10), disregard step 5 and move on to step 6.

5. Locate the 1/4" red tubing. One end is connected to the RO filter assembly. See Fig 24.
 - A. Route the loose end of the red tube through countertop to faucet.
 - B. Cut the loose end of the red tube square and to length. See Fig. 19 for tube cutting instructions.

NOTE: Tubing lengths should allow for the removal of the assembly from the hanger washers for servicing. If tubing lengths are shortened for neater appearance, it may be necessary to keep the assembly on the hanger washers for service.

- C. Insert all the way onto the 1/4" faucet barb fitting on faucet. See Figure 17.
6. Feed a length of 3/8" black tubing up through the hole and connect to the 3/8" barb on the bottom of the faucet. See Figure 16. The other end of this tubing will be connected to the drain, as shown on page 15.
 7. Mount the faucet body on to the faucet base, 1/4 turn. See Figure 16.

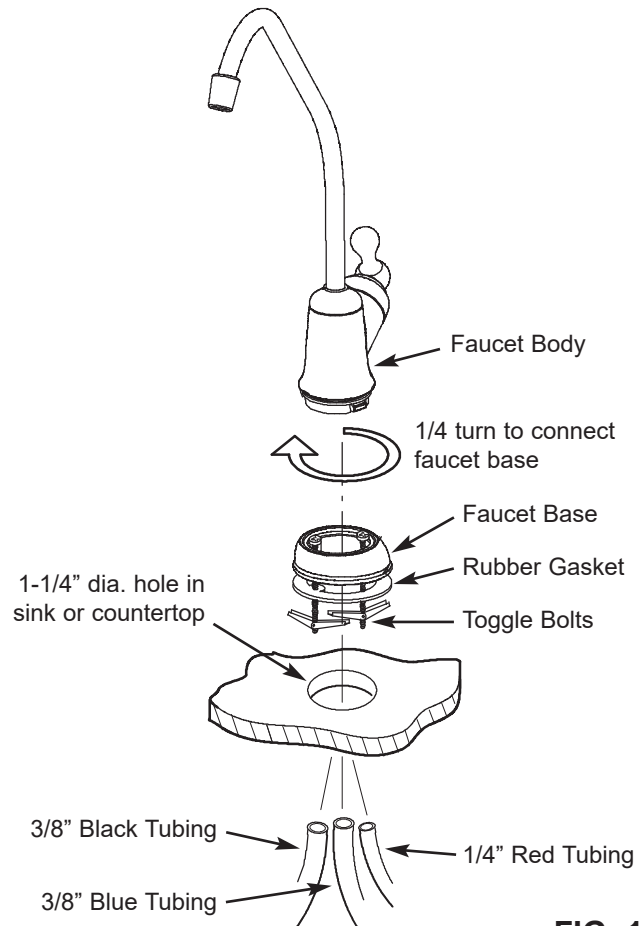

FIG. 16

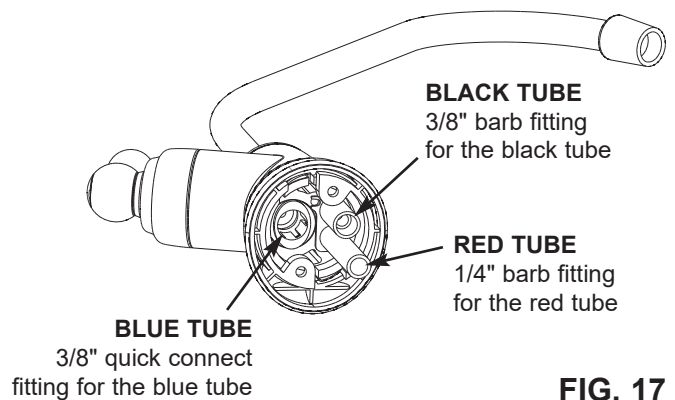

FIG. 17

Step F - Connect Tubes

HOW TO CUT AND CONNECT THE TUBES

Your Reverse Osmosis system includes push-in fittings for quick tubing connection. Review the following instructions before connecting the tubes in the next step. Failure to follow these instructions may lead to future leaks.

Cut tubes to length

1. Use a sharp cutter or knife to cut the end of tubing. Always cut the tubing square. See Fig. 19.
2. Inspect the tube up to 1" from the end to be sure there are no nicks, scratches or other rough spots. If needed, cut the tubing again. See Fig. 19.

NOTE: Tubing lengths should allow for the removal of the assembly from the hanger washers for servicing. If tubing lengths are shortened for neater appearance, it may be necessary to keep the assembly on the hanger washers for service.

Connect tubes

NOTE: Remove protective foam plugs before connecting tubes (See Fig. 18). Discard foam plugs.

1. Push tubing through collet, until it engages the o-ring. See Fig. 20. Continue pushing until the tube bottoms out against the back of the fitting. See Fig. 21. Do not stop pushing when the tube engages the o-ring. Failure to follow these instructions may lead to future leaks. When a 1/4" tube is fully engaged, 11/16" of the tube has entered the fitting. When a 3/8" tube is fully engaged, 3/4" of the tube has entered the fitting. Mark tube with a piece of tape or marker. See Figs. 20 & 21.

2. If additional tubing is required, see parts list at the end of this manual.

To Disconnect Tubes

1. Push the collet inward with a finger tip. See Fig. 23.
2. Continue holding collet inward while pulling the tubing out. See Fig. 23.

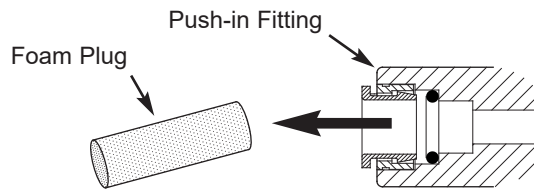

Remove and Discard Foam Plugs

FIG. 18

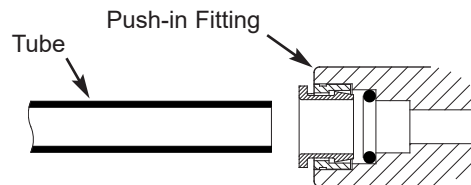

Cut tubing square with end of tubing round, smooth, with no cuts, nicks or flat spots.

Tube Correctly Cut

FIG. 19

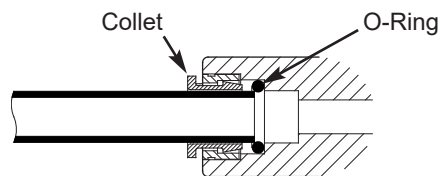

Tube Partially Engaged with Fitting

FIG. 20

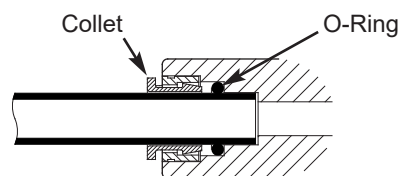

Tube Fully Engaged with Fitting

FIG. 21

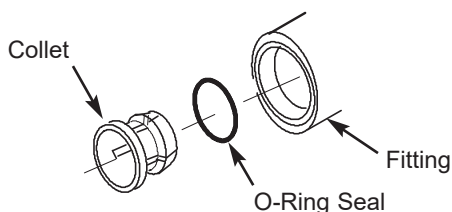

Collet and O-Ring

FIG. 22

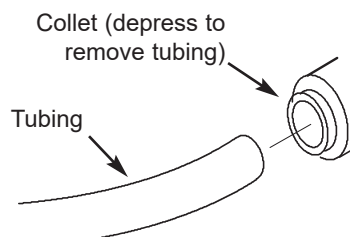

Disconnect Tubing

FIG. 23

Step F - Connect Tubes (cont.)

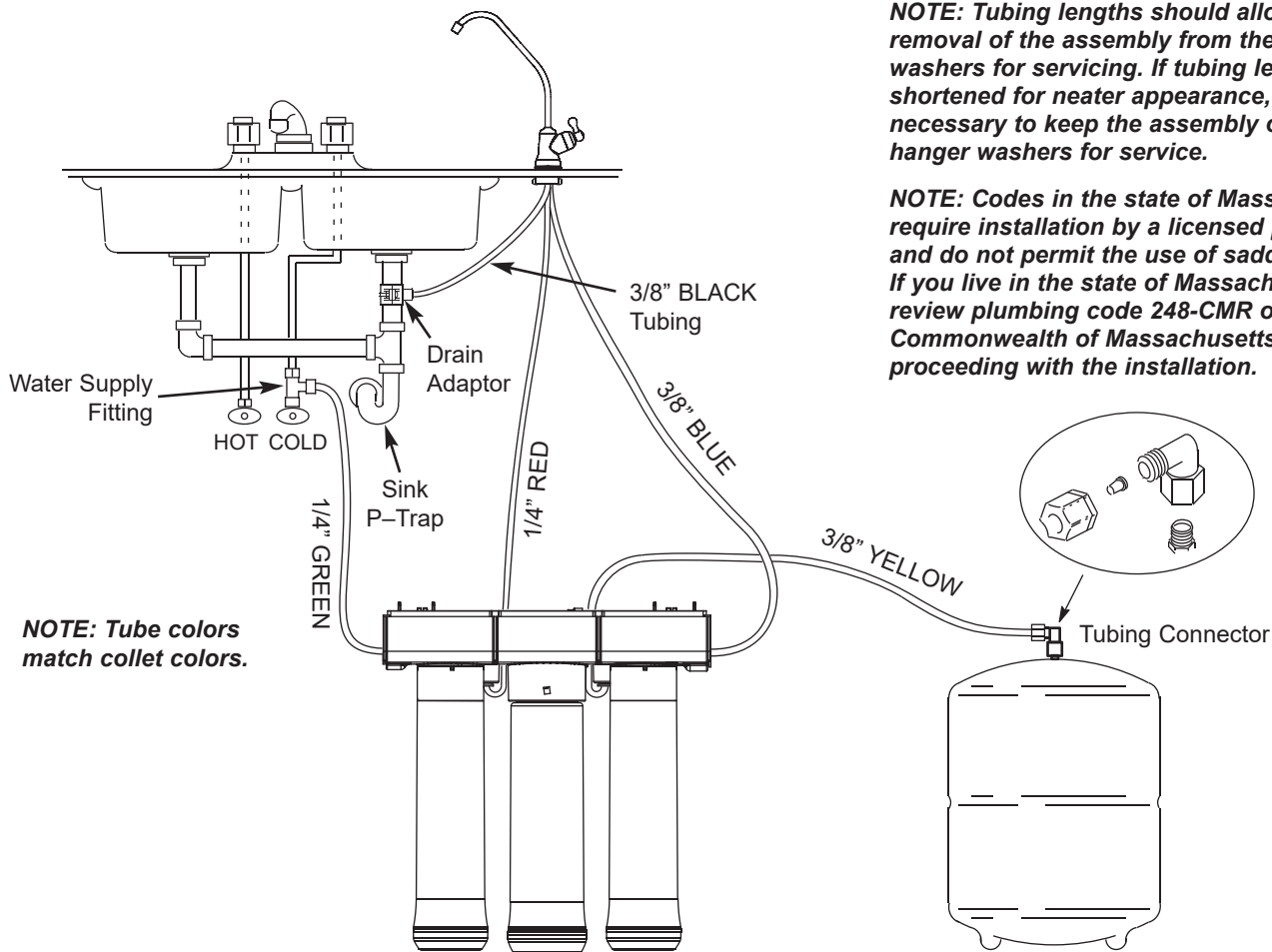

NOTE: Tube colors match collet colors.

NOTE: Tubing lengths should allow for the removal of the assembly from the hanger washers for servicing. If tubing lengths are shortened for neater appearance, it may be necessary to keep the assembly on the hanger washers for service.

NOTE: Codes in the state of Massachusetts require installation by a licensed plumber and do not permit the use of saddle valves. If you live in the state of Massachusetts, review plumbing code 248-CMR of the Commonwealth of Massachusetts before proceeding with the installation.

Tube Connections

FIG. 24

ROUTE YELLOW TUBE TO STORAGE TANK

1. Locate the yellow tube attached to the Reverse Osmosis filter assembly.
2. Route the loose end of the yellow tube to the fitting on top of the storage tank. See Fig. 24.
3. Cut tube square and to length. See Fig. 19.
4. Do not connect at this time. This will occur in the sanitizing step.

CONNECT GREEN TUBE TO COLD WATER SUPPLY PIPE

1. Route one end of the 1/4" green tube to the fitting on the water supply pipe. See Fig. 24.
2. Cut tube square and to length. See Fig. 19.
3. Connect to tee feed adaptor. See Fig. 7. Insert all the way into the fitting. See Figs. 20 & 21.
4. Route the other end of the green tube to green collet to the fitting on the left side of the Reverse Osmosis filter assembly.
5. Cut tube square and to length. See Fig. 19.
6. Insert all the way into the fitting. See Figs. 20 & 21.
7. Pull on the tube to be sure it is held firmly in the fitting.

CONNECT BLUE TUBE TO REVERSE OSMOSIS ASSEMBLY

1. Locate the blue tube attached to the faucet.
2. Route the loose end of the 3/8" blue tube to the blue collet on the right side of the Reverse Osmosis filter assembly.
3. Cut tube square and to length. See Fig. 19.
4. Insert all the way into the fitting. See Figs. 20 & 21.
5. Pull on the tube to be sure it's held firmly in the fitting.

CONNECT BLACK TUBE FROM REVERSE OSMOSIS FAUCET TO DRAIN ADAPTER

1. Locate the 3/8" black tube attached to the faucet. Fig. 24.
2. The loose end needs to be attached to the quick connect fitting on the sink drain adapter.
3. Cut this tube as needed to route it as straight as possible, without loops, dips, or kinks.
4. Cut the end of the tube square. See Fig. 19.
5. Insert all the way into the fitting. See Figs. 20 & 21.
6. Pull on the tube to be sure it is held firmly in the fitting.

RED TUBE TO REVERSE OSMOSIS FAUCET

The red tube connection was completed in the faucet assembly steps.

Step G - Sanitize, Test and Purge System

SANITIZE THE SYSTEM

Sanitizing is recommended immediately after installation of the Reverse Osmosis system. It's also recommended after servicing inner parts. It is important that the person installing or servicing the system have clean hands while handling inner parts of the system.

Complete the following steps to sanitize the system. See Fig. 25.

1. Make sure that the water supply to the Reverse Osmosis system is off.
2. Open the Reverse Osmosis faucet. If the tank is not already empty, allow the water to empty.
3. Locate the eyedropper included in parts bag and common household bleach (5.25%).
4. Add 3 ml. of bleach into open end of yellow tubing. Handle bleach according to bleach manufacturer's recommendations. See Fig. 25.
5. Connect yellow tubing to tank connector. See Figs. 14 and 25.
6. Sanitizing the system will be completed during the pressure test and purging steps on the following page.

NOTE: The bleach must be removed from the system before drinking the water. See purging instructions on the next page.

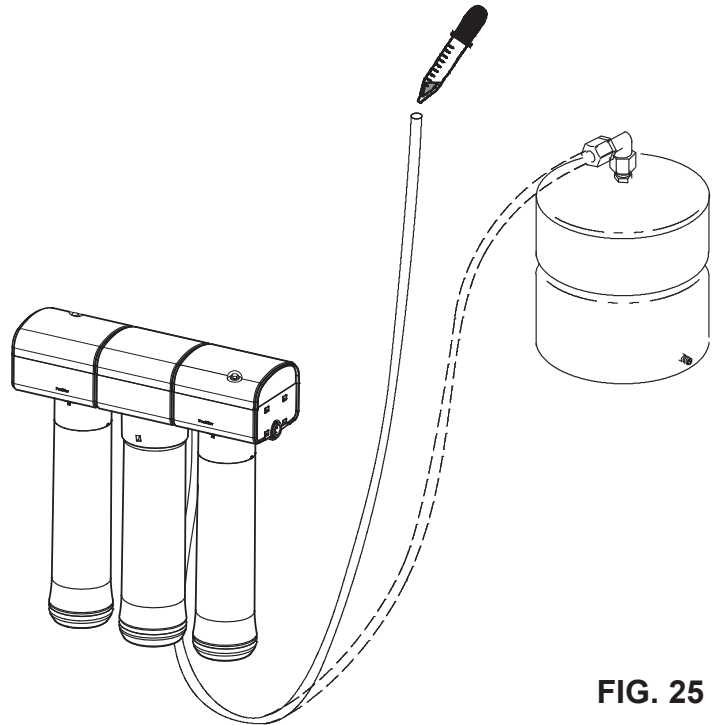

FIG. 25

Manufacturer recommends using the Model 7301203 Sanitizing Kit

This reusable sanitizing kit (not included) is recommended to easily and completely sanitize your Reverse Osmosis system annually.

The kit includes the following:

- Prefilter sanitization cartridge (contains no filtration media)
- Postfilter sanitization cartridge (contains no filtration media)
- RO sanitization cartridge (contains no RO membrane)
- Syringe, 1 oz.
- Complete instructions

Uses standard 5.25% household bleach (not included) to completely sanitize the Reverse Osmosis system.

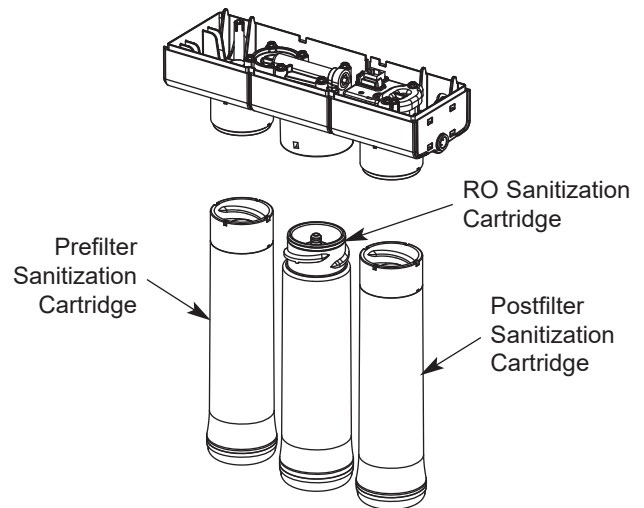

To order, go to

www.ecopure.com

and click on the "Replacement Parts" link under the "Owner Center" tab,

or call toll free 1-800-693-1138

Step G - Sanitize, Test and Purge System (cont.)

PRESSURE TEST THE SYSTEM

NOTE: Complete the sanitizing procedures on the preceding page before pressure testing.

To pressure test the system, complete the following steps.

1. Open the water supply valve to the Reverse Osmosis system.
2. Purge air from the house plumbing by opening several house faucets. Close faucets when water runs smooth, with no spurting.
3. Pressure will start to build in the RO system. In about 2 hours check all fittings and connections. Check for water leaks. Fix leaks if any are found. If problems exist, refer to the troubleshooting chart or call the toll free number below).

NOTE: When the system is first pressurized, water may "spurt" from the faucet air gap hole until air is expelled from the RO system.

Please review the following operating features before using your Reverse Osmosis system:

You will **not** have filtered water immediately. It may take several hours to fill the storage tank and create maximum flow from the Reverse Osmosis faucet.

Water Pressure from the Reverse Osmosis faucet will be less than your standard faucet.

Water will run to the drain while the Reverse Osmosis system is producing water, even if you are not drawing water from the Reverse Osmosis faucet. You may hear a small quantity of water going to the drain at times when water is not being used. This is normal. Water going to the drain will automatically shut off when the storage tank is full.

PURGING THE SYSTEM

To purge the system, complete the following steps.

1. Open the Reverse Osmosis Faucet and let water flow through the system for a 24 hour period. Water flow will be a slow trickle at this time.
NOTE: Do not consume water from the RO system until purging is complete.
2. Close the Reverse Osmosis faucet after the 24 hour purging period is complete.
3. When the purging is finished, your Reverse Osmosis system is ready for use.

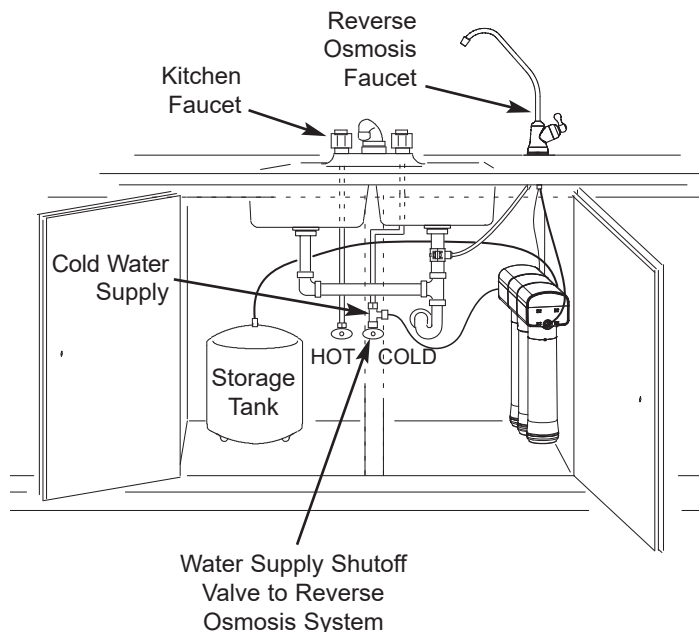

FIG. 26

NOTE: Codes in the state of Massachusetts require installation by a licensed plumber and do not permit the use of saddle valves.

If you live in the state of Massachusetts, review plumbing code 248-CMR of the Commonwealth of Massachusetts before proceeding with the installation.

NOTE: As with all other water system applications, leaks may occur. Because the system pressure builds slowly, leaks may not be immediately apparent. Recheck for leaks 24 hours after purging the system is complete.

How Your RO Water System Works

HOW YOUR REVERSE OSMOSIS SYSTEM WORKS

Introduction: Your Reverse Osmosis (RO) Drinking Water System uses your household water pressure to force water through three filters. Minerals and impurities are filtered out. Delicious tasting drinking water goes to the storage tank-ready for your use. Minerals and impurities are sent down the drain. The following paragraphs will explain in detail how your Reverse Osmosis Drinking Water System works.

Prefilter: Water from the cold supply pipe enters the prefilter. See Fig. 27. The prefilter is a replaceable sediment cartridge with activated carbon in its composition. The cartridge reduces taste, odor, sand, silt, dirt, other sediments, and up to the amount of chlorine shown in the specifications.

Reverse Osmosis Cartridge: Filtered water flows from the prefilter to the Reverse Osmosis membrane cartridge. See Fig. 27. The Reverse Osmosis cartridge is a tightly wound special membrane. The membrane reduces the dissolved solids and organic matter. High quality product water (about one ounce per minute) exits the Reverse Osmosis cartridge. The product water flows to the storage tank, postfilter or Reverse Osmosis faucet. Drain water, with the dissolved solids and organic matter, is routed to the drain.

Storage Tank: The storage tank holds product water. See Fig. 27. A diaphragm inside the tank holds water pressurized to about half of supply water pressure when the tank is full. This provides fast flow to the Reverse Osmosis faucet. When the tank is empty of water, the pressure at the air valve is 5 - 7 psi.

Postfilter: Water goes through the postfilter before going to the Reverse Osmosis faucet. See Fig. 27. The postfilter is an activated carbon type filter. Any remaining tastes and odors are reduced from the product water. Clean, high quality drinking water is available at the faucet.

Reverse Osmosis Faucet: The sink or countertop faucet has a hand operated knob to dispense drinking water. See Fig. 27. An air-gap is built into the faucet drain water connection to comply with plumbing codes.

Shutoff Assembly: The unit has an automatic shutoff system to conserve water. When the storage tank has filled to capacity, and the drinking water faucet is closed, pressure closes the shutoff to stop flow to the drain. After enough drinking water is used, pressure in the system drops, and the shutoff opens to allow the tank to be refilled. See Fig. 27.

Check Valve: A check valve is located in the Reverse Osmosis manifold above the center cartridge. The check valve prevents a backward flow of product water from the storage tank to drain. A backward flow could damage the Reverse Osmosis Membrane. See Fig. 27.

Flow Control: Water flow to the drain is restricted by the flow control. It maintains the desired flow rate to obtain the highest quality drinking water. The flow control is located inside the elbow fitting on the Reverse Osmosis manifold drain port. See Fig. 27.

Questions? Call Toll Free 1-800-693-1138 or visit www.ecopure.com

When you call, please be prepared to provide the model, date code and serial number, found on the rating decal, located inside the cover.

How Your RO Water System Works

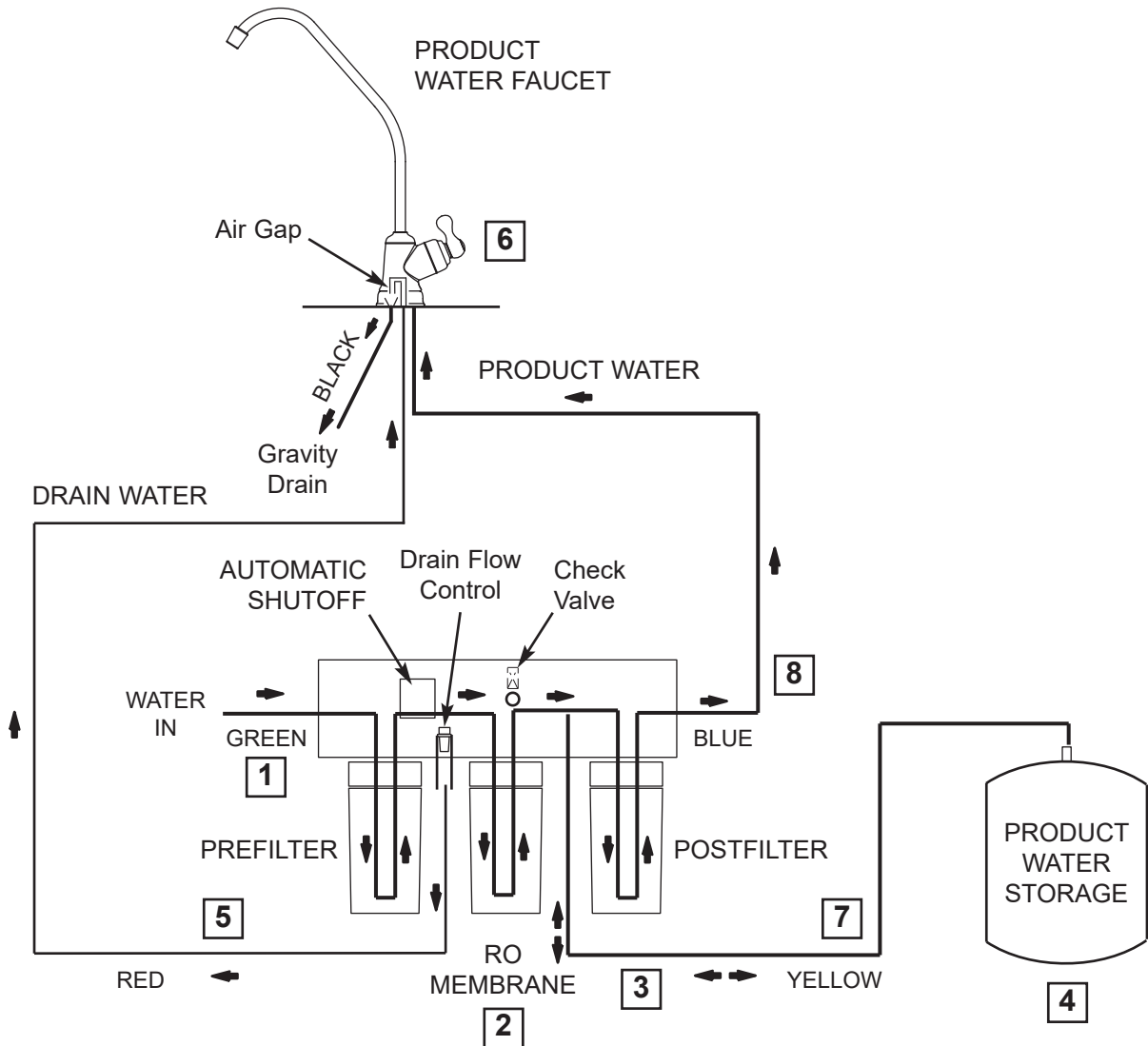

Reverse Osmosis Water Flow Schematic

FIG. 27

Water Flow Description

1. Water enters prefilter. Sand, silt and other sediments are reduced. Chlorine is also reduced. See Fig. 27.
2. Water leaves prefilter and proceeds to the Reverse Osmosis Cartridge.
3. Water enters the Reverse Osmosis membrane. Dissolved solids are reduced.
4. Processed water leaves the Reverse Osmosis Membrane and flows to the storage tank.
5. Drain water with dissolved solids leaves the Reverse Osmosis membrane and flows to the drain.
6. Faucet is activated.
7. Processed water leaves the storage tank and flows to the postfilter, where it is filtered to ensure fresh taste.
8. Water flows to the Reverse Osmosis faucet.

Maintenance

PREFILTER / POSTFILTER MAINTENANCE

NOTE: It is recommended to replace the prefilter and postfilter cartridges at least every 6 months of product water use. Replace more often if they begin to plug with sediment.

The prefilter and postfilter are replaceable sediment cartridges with activated carbon in their composition. See Fig. 28. You must periodically replace the prefilter and postfilter cartridge. This will protect the RO membrane from being destroyed by chlorine. It will also prevent the filters from plugging with sediment.

You may notice a slower output of product water as the prefilter and postfilter build up with sediment. Replace the prefilter and postfilter cartridges when this occurs.

RO MEMBRANE CARTRIDGE MAINTENANCE

The Reverse Osmosis cartridge is a tightly wound special membrane. See Fig. 28. The membrane reduces the *dissolved* solids and organic matter. The life of the Reverse Osmosis membrane cartridge depends mostly on the pH and hardness of the supply water (see Specifications). Cartridge life is shorter with higher pH. For example, if supply water pH is from 6.8 to 7.7, the cartridge may last for well over one year. However, cartridge life may be as short as 6 months if the pH is as high as 8.5 to 10. Higher pH weakens the cartridge membrane and causes pin-hole leaks. It's time to replace the Reverse Osmosis cartridge when the production rate and/or quality of product water drops. Product water may begin to taste different, indicating solids and organics are passing through the Reverse Osmosis membrane. See Reverse Osmosis cartridge replacement.

REVERSE OSMOSIS CARTRIDGE REPLACEMENT

Complete the following steps to replace the cartridges.

NOTE: Do not remove manifold from mounts. Flexing or twisting may damage the manifold.

1. Remove (turn to the left) the prefilter cartridge from the manifold to stop flow to the Reverse Osmosis cartridge.
2. Remove the Reverse Osmosis cartridge.
3. Remove the postfilter cartridge.
4. Discard the cartridges in a proper manner.
5. Install new cartridges in reverse order (post filter, Reverse Osmosis and then prefilter). Turn cartridges to the right to reattach to the filter heads. Do not overtighten.
6. Purge the Reverse Osmosis system. See page 17 for instructions.

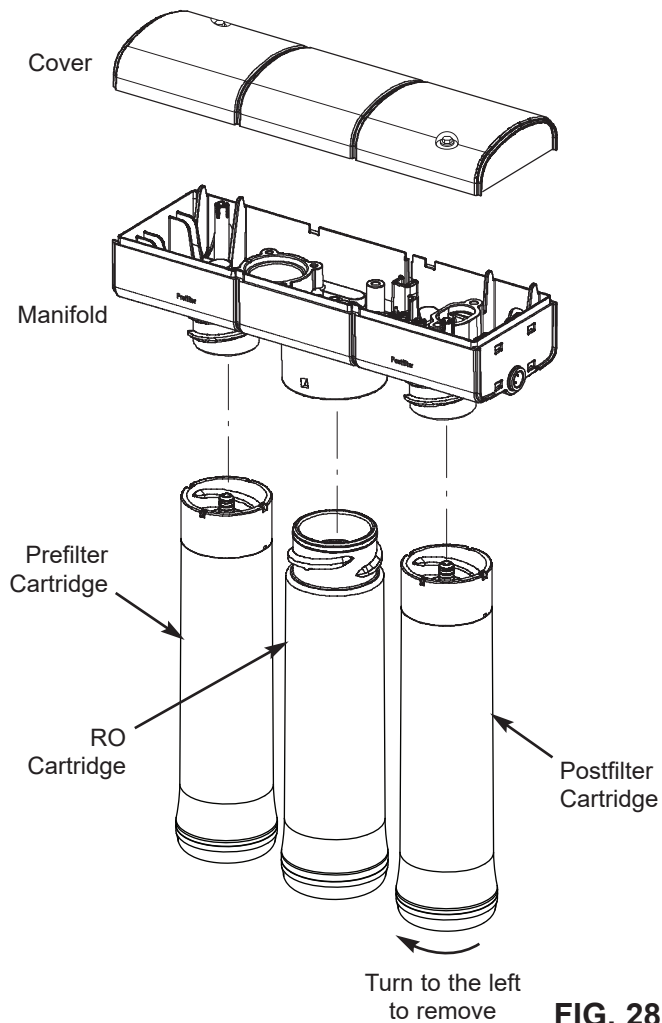

PREFILTER / POSTFILTER CARTRIDGE REPLACEMENT

Complete the following steps to replace the cartridges.

NOTE: Do not remove manifold from mounts. Flexing or twisting may damage the manifold.

1. Remove the prefilter cartridge (turn to the left) from the filter head. Then remove the postfilter cartridge.
2. Discard the cartridges in a proper manner.
3. Install new cartridges in reverse order (postfilter first, then prefilter). Turn cartridges to the right to reattach to the filter heads. Do not overtighten.
4. Purge the Reverse Osmosis system. See page 17 for instructions.

Maintenance

FLOW CONTROL

The flow control is required for proper operation of the Reverse Osmosis system. See Fig. 29. The flow control, located inside the push-in elbow fitting on the drain port of the system housing, keeps water flowing through the membrane at the required rate. This ensures that the system produces the best quality product water.

Periodically check the flow control to be sure the small hole through it is clean and unrestricted.

If the flow control requires service, review the exploded view in Fig. 29. Assemble and disassemble as shown. If the flow control remains in the manifold when the push-in elbow fitting is removed, you will need to remove the drain port's collet and o-ring, as shown in the next section, to retrieve it.

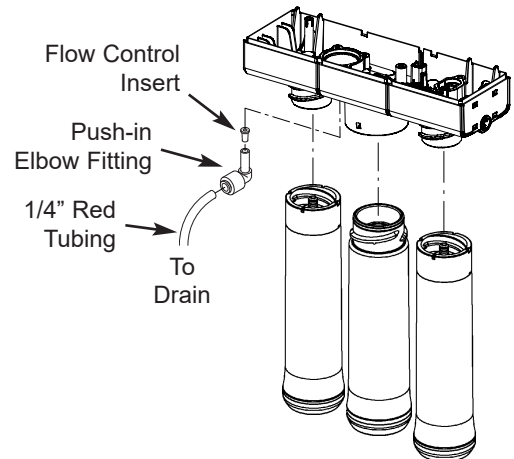
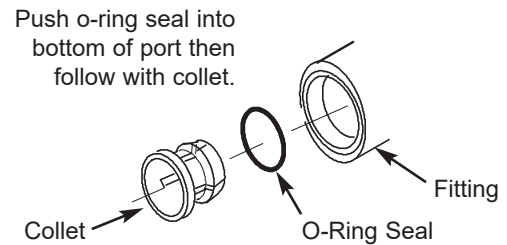

FIG. 29

CHANGE COLLET AND O-RING

1. Remove the collet and o-ring from the fitting with a small screwdriver. Do not scratch the internal walls of the collet port. See Figs. 30 & 31.
2. Clean collet port, lubricate with silicone-based lubricant, and insert the o-ring seal into the bottom of the port. See Figs. 30 & 31.
3. Push the collet inward until it locks in place. See Figs. 30 & 31.



Change Collet and O-Ring FIG. 30

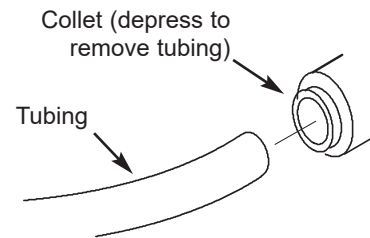

Disconnect Tubing FIG. 31

Troubleshooting

Problem: Chlorine taste and/or odor in the RO product water.	
Cause: The level of chlorine in your water supply exceeds maximum limits, and has destroyed the Reverse Osmosis membrane.	Correction: If the water supply contains more than 2.0 ppm of chlorine, additional filtering of the water supply to the Reverse Osmosis is needed. Contact your local water supplier. Correct this condition before doing maintenance on the Reverse Osmosis system.
Cause: The prefilter is no longer removing chlorine from the water supply.	Correction: Replace the prefilter, postfilter and Reverse Osmosis membrane cartridges. See Page 20.
Problem: Other taste and/or odor.	
Cause: Postfilter expended.	Correction: Replace the postfilter cartridge. If taste and odor persist, replace the prefilter cartridge and Reverse Osmosis membrane cartridge. See Page 20.
Cause: Reverse Osmosis membrane cartridge expended.	
Cause: Contamination in product water storage tank.	Correction: Use sanitizing procedures. Replace prefilter and postfilter cartridges. See page 16.
Cause: System contamination.	Correction: Sanitize entire system. Call 1-800-693-1138 for instructions.
Problem: System makes product water too slowly.	
Cause: Water supply to the Reverse Osmosis system not within specifications.	Correction: Increase water pressure, precondition the water, etc., as needed to conform before doing maintenance on the Reverse Osmosis system.
Cause: Prefilter or Reverse Osmosis membrane cartridges plugged with sediment.	Correction: Replace the prefilter cartridge. If rate does not increase, replace the postfilter cartridge and Reverse Osmosis membrane cartridge. See Page 20.
Problem: System makes lower amount of product water than usual.	
Cause: Storage tank air-charge less than 5-7 psi.	Correction: Open Reverse Osmosis faucet and drain tank until flow slows to a drip. Keep faucet open and check tank pressure. If low, pressurize to 6 psi. Close faucet to refill the tank.
Problem: High total dissolved solids (TDS) in product water	
Cause: Water supply to the Reverse Osmosis system not within specifications.	Correction: Increase water pressure, precondition the water, etc., as needed to conform before doing maintenance on the Reverse Osmosis system. Correction: Send treated and untreated water samples to a water analysis lab for testing. It is important to test both the treated and untreated water to determine system performance. If the TDS is not within the system's performance guidelines, replace the prefilter, post filter and RO membrane cartridges.
Cause: Plugged drain flow control insert.	Correction: Replace drain flow control insert. See page 21.
Problem: Continual water flow to drain and low or no water production.	
Cause: Missing flow control insert in drain port.	Correction: Make sure flow control insert is in place. See page 21.
Problem: Water leaking from faucet airgap hole.	
Cause: Drain side of faucet airgap (3/8" black tubing) plugged, restricted or incorrectly connected to drain point..	Correction: Inspect and eliminate restriction or plug. Check that drain line is routed properly. Refer to installation instructions for proper drain connection. See pages 6 & 10.

Troubleshooting

Problem: Water leaks at push connect fittings	
Cause: Tubing not cut square.	Correction: Cut tubing square. See pages 14 & 15.
Cause: Tubing not pushed in all the way.	Correction: Push tubing in all the way. See pages 14 & 15.
Cause: Tubing nicked.	Correction: Remove tube from connection. Remove nicked portion by cutting tube to shorter length. Reinsert in connection. See pages 14 & 15. If removing the drain line, leave in place the elbow fitting that it connects to. See page 21.
Cause: Outer tubing surface finish not smooth.	Correction: Remove tube from connection. Remove problem area by cutting tube to shorter length. Reinsert in connection. See pages 14 & 15. If removing the drain line, leave in place the elbow fitting that it connects to. See page 21.

Need help troubleshooting? Call Toll Free 1-800-693-1138 or visit **www.ecopure.com**

When you call, please be prepared to provide the model, date code and serial number, found on the rating decal, located inside the cover.

Exploded View

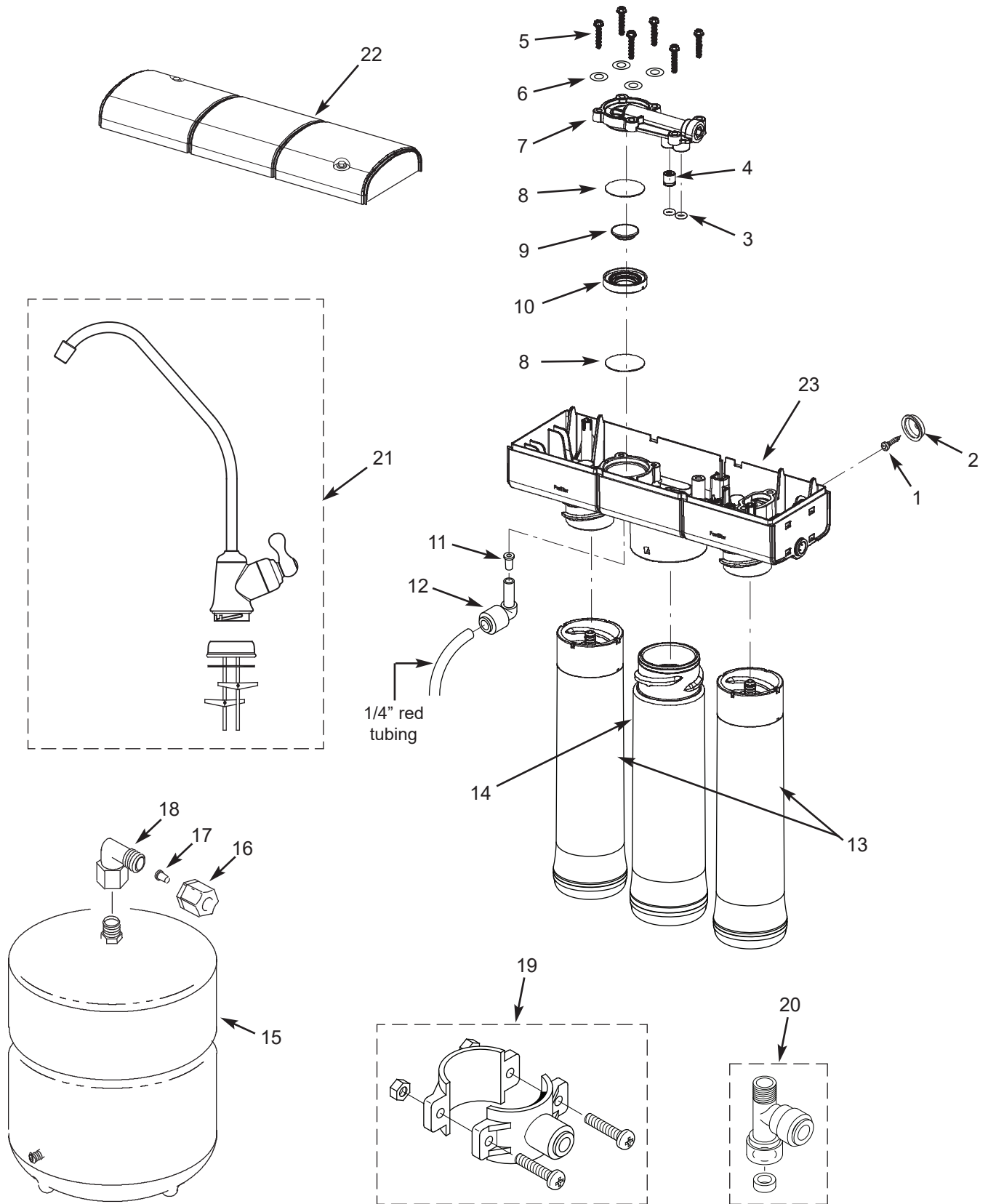

Parts List

Key No.	Part No.	Description
–	7333129	Mounting Hardware Kit (includes 2 ea. of Key Nos. 1 & 2)
1	↑	Screw (2 req'd)
2	↑	Hanger Washer (2 req'd)
–	7333137	Check Valve Kit (includes Key No. 4 & 2 of Key No. 3)
3	↑	O-ring, Auto. Shutoff Cover (2 req'd)
4	↑	Check Assembly
–	7333145	Automatic Shutoff Kit (incl. Key No. 7, 4 of Key No. 6 & 6 of Key No. 5)
5	↑	Screw (6 req'd)
6	↑	Washer (4 req'd)
7	↑	Automatic Shutoff Cover Assembly
–	7333179	Diaphragm Kit (includes Key Nos. 9, 10 & 2 of Key No. 8)
8	↑	Diaphragm (2 req'd)
9	↑	Plunger
10	↑	Spacer Ring
–	7333153	Flow Control Kit (includes Key Nos. 11 & 12)
11	↑	Flow Control Insert
12	↑	Elbow, Plug-in, 1/4 Stem x 1/4 Tube

Key No.	Part No.	Description
13	ECOROF	Pre & Post Filter Cartridge *
14	ECOROM	RO Membrane Cartridge *
15	7205326	Storage Tank
–	7333161	Tank Connector Kit (includes Key No. 16-18)
16	↑	Nut, 3/8" Tubing
17	↑	Insert, 3/8" Tubing
18	↑	Connector, 1/4 NPT x 3/8 Jaco
19	119-8600123	Drain Adapter
20	119-8600084	Water Supply Fitting, 1/4" Q.C.
21	7308043	Faucet with Base, Chrome
22	7400099	Cover
23	7285368	Repl. Head Assembly (includes Key Nos. 3-10 assembled, & Key No. 22)
■	7301203	Sanitization Kit ●
■	7315189	Auxiliary Storage Tank ●
■	7161823	Tubing, 1/4" x 20' - white ▲ ●
■	7157280	Tubing, 3/8" x 20' - white ▲ ●
■	7279749	Dropper

* Please purchase replacement cartridges from the retailer where you bought your reverse osmosis system.

■ Not illustrated.

● Not included.

▲ Tubing lengths for remote installations, direct replacement for colored lengths of tubing.

NOTE: Codes in the state of Massachusetts require installation by a licensed plumber and do not permit the use of saddle valves.

To order repair parts call toll free 1-800-693-1138.

Manufactured and warranted by
Water Channel Partners
1890 Woodlane Drive
Woodbury, MN 55125

EXTEND YOUR WARRANTY:

You can turn your R.O. system's one year factory warranty into a lifetime warranty by saving your receipts for purchases of EcoPure replacement R.O. membrane and filter cartridges. See "Lifetime Warranty" below for details.

WARRANTY

REVERSE OSMOSIS WATER FILTRATION SYSTEM - MODEL ECOP30 (not including filter cartridges and R.O. membrane)

Warrantor: Water Channel Partners, 1890 Woodlane Drive, Woodbury, MN 55125

One Year Warranty:

Warrantor guarantees, to the original purchaser when the product is purchased from an authorized dealer, and when installed and maintained in accordance with the instructions, that the Reverse Osmosis Water Filtration System (ECOP30) will be free from defects in materials and workmanship and will perform in accordance with its written specifications for a period of one (1) year from the date the product is delivered.

Lifetime Warranty:

Warrantor guarantees, to the original purchaser only, that the Reverse Osmosis Water Filtration System (ECOP30) will be free from defects in materials and workmanship and will perform in accordance with its written specifications for the lifetime of the purchaser, provided that:

- The product is purchased from an authorized dealer.
- The system is installed and maintained in accordance with the instructions in the same home where it was originally installed.
- The purchaser replaces both the pre and post filters every six (6) months and saves their receipts, for proof of purchase of the EcoPure ECOROF filter cartridge set, in case a warranty claim is made. Purchase of no more than two (2) ECOROF filter sets in a 12 month period may be applied toward compliance with this warranty.
- The purchaser replaces the R.O. membrane every two (2) years and saves their receipts, for proof of purchase of the EcoPure ECOROM membrane, in case a warranty claim is made. Purchase of no more than one (1) ECOROM membrane cartridge in a 24 month period may be applied toward compliance with this warranty.

Failure to adhere to the above requirements from the date the product is delivered voids the lifetime warranty.

If, during such respective period, a part proves, after inspection, to be defective, Warrantor will, at its sole option, either replace or repair the part without charge except normal shipping and installation charges. If a repair or replacement part is unavailable, Warrantor may refund the original purchase price. Labor to maintain the equipment is not part of the warranty. Filters and membranes, which are expendable, are not covered by the warranty.

If you have questions regarding a warranted product, need assistance with installation or troubleshooting, wish to order a part or report a warranty issue, we are just a phone call away. SIMPLY DIAL 1-800-693-1138 for assistance.

General Provisions

The above warranties are effective provided the Reverse Osmosis Water Filtration System is operated at water pressures not exceeding 100 psi (7.0 kg/cm²), and at water temperatures not exceeding 100°F (38°C); provided further that the Reverse Osmosis Water Filtration System is not subject to abuse, misuse, alteration, neglect, freezing, accident or negligence; and provided further that the Reverse Osmosis Water Filtration System is not damaged as the result of any force of nature such as, but not limited to, flood, hurricane, tornado or earthquake.

The limited warranty does not cover damage due to: (a) transportation, (b) storage, (c) improper use, (d) failure to follow the product instructions or to perform any preventive maintenance, (e) modifications, (f) unauthorized repair, (g) normal wear and tear, or (h) external causes such as accidents, abuse, or other actions or events beyond Warrantor's reasonable control. Use of aftermarket, used, or non-manufacturer provided parts will void all warranties. Warranty does not cover failures due to improper product installation. Warrantor is excused if failure to perform its warranty obligations is the result of strikes, government regulation, materials shortages, or other circumstances beyond its control.

THERE ARE NO WARRANTIES ON THE REVERSE OSMOSIS WATER FILTRATION SYSTEM BEYOND THOSE SPECIFICALLY DESCRIBED ABOVE. ALL IMPLIED WARRANTIES, INCLUDING ANY IMPLIED WARRANTY OF MERCHANTABILITY OR OF FITNESS FOR A PARTICULAR PURPOSE, ARE DISCLAIMED TO THE EXTENT THEY MIGHT EXTEND BEYOND THE ABOVE PERIODS. THE SOLE OBLIGATION OF WARRANTOR UNDER THESE WARRANTIES IS TO REPLACE OR REPAIR THE COMPONENT OR PART WHICH PROVES TO BE DEFECTIVE WITHIN THE SPECIFIED TIME PERIOD, AND WARRANTOR IS NOT LIABLE FOR CONSEQUENTIAL OR INCIDENTAL DAMAGES. NO DEALER, AGENT, REPRESENTATIVE, OR OTHER PERSON IS AUTHORIZED TO EXTEND OR EXPAND THE WARRANTIES EXPRESSLY DESCRIBED ABOVE.

Some states do not allow the exclusion or limitation of incidental or consequential damages, so the above limitation or exclusion may not apply to you. This warranty gives you specific legal rights, and you may have other rights which vary from state to state. This warranty applies to consumer-owned installations only.

Performance Data



Reverse Osmosis Filter System Model ECOP30

IMPORTANT NOTICE: Read this performance data and compare the capabilities of this unit with your actual water treatment needs. It is recommended that, before purchasing a water treatment unit, you have your water supply tested to determine your actual water treatment needs. This filter system is designed to be used for the reduction of the substances listed below. Do not use where water is microbiologically unsafe or of unknown quality, without adequate disinfection before or after the system. Systems certified for cyst reduction may be used on disinfected water that may contain filterable cysts. This system has been tested for the treatment of water containing pentavalent arsenic (also known as As (V), As (+5), or arsenate) at concentrations of 0.30 mg/L or less. This system reduces pentavalent arsenic, but may not reduce other forms of arsenic. This system shall be used on water supplies containing a detectable free chlorine residual at the system inlet or on water supplies that have been demonstrated to contain only pentavalent arsenic. Treatment with chloramine (combined chlorine) is not sufficient to ensure complete conversion of trivalent arsenic to pentavalent arsenic. Please see the Arsenic Facts section on page 28 for further information. While testing was performed under standard laboratory conditions, actual performance of this system may vary based on local water conditions. Some or all of the contaminants reduced by this unit may not be in your water supply. See elsewhere in this owner's manual for further instructions on filter replacement, system installation, operating procedures, and warranty. The maintenance instructions must be followed for the product to perform as indicated below.

General Information

This product is an undercounter system that filters and stores quality drinking water ready for use. It contains a carbon sediment filter, RO membrane, and an activated carbon post filter. This system has been tested according to NSF/ANSI 58 and 42 for reduction of substances listed below. The concentration of the indicated substances in water entering the systems were reduced to a concentration less than or equal to the permissible limit for water leaving the system, as specified in NSF/ANSI 58. The testing was performed using spiked chlorine free deionized water with ≤ 1 NTU turbidity, 7.5 ± 0.5 pH, $25 \pm 1^\circ\text{C}$, and $1\mu\text{S/cm}$ conductivity.

Maintenance

Replacement filter prices may vary. Estimated costs of replacement filter elements (part number ECOROF), or replacement membranes (part number ECOROM), range from \$39 to \$59.

Application Specifications for Feed Water

Pressure	40-100 psig (2.8-7.0 kg/cm ²)
Temperature.....	40-100°F (5-38°C)
Maximum TDS Level.....	2000 mg/L
Maximum Hardness @ 6.9 pH	10 gpg ¹ (171 mg/L)
Maximum Iron, Manganese, Hydrogen Sulfide.....	0 mg/L
Maximum Chlorine	2.0 mg/L ²
pH Range	4-10

¹ Grains per gallon.

² A carbon prefilter is part of this system to protect the reverse osmosis membrane from deterioration should there be chlorine in the supply water. This reverse osmosis system contains a replaceable treatment component critical for effective reduction of TDS. The product water shall be tested periodically to verify that the system is performing satisfactorily.

Performance Data

PERFORMANCE CLAIMS FOR ECOP30					
Substance	NSF Required Influent Challenge Concentration (mg/L) ¹	NSF Max. Permissible Product Water Concentration (mg/L) ¹	Average Influent (mg/L) ¹	Avg. / Max. Effluent (mg/L) ¹	Avg. / Min. Percent Reduction
Arsenic (pentavalent) ²	0.30 ±10%	0.010	0.300	0.002 / 0.005	99.3 / 98.3
Barium ²	10 ±10%	2.0	9.1	0.12 / 0.32	98.6 / 96.5
Cadmium ²	0.03 ±10%	0.005	0.032	0.0005 / 0.0009	98.6 / 97.2
Chromium (VI) ²	0.3 ±10%	0.1	0.280	0.003 / 0.008	98.8 / 97.1
Chromium (III) ²	0.3 ±10%	0.1	0.310	0.003 / 0.004	99.2 / 97.1
Copper ²	3.0 ±10%	1.3	3.0	0.049 / 0.089	98.4 / 98.4
Cysts ²	≥50,000 #/mL ⁴	99.95% ³	160,000 #/mL ⁴	9 / 29 #/mL ⁴	99.99 / 99.98
Fluoride	8.0 ±10%	1.5	8.6	0.4 / 0.6	94.9 / 93.1
Lead ²	0.15 ±10%	0.010	0.15	0.0014 / 0.0025	99.0 / 98.4
Nitrate plus Nitrite (as N) ¹¹	30 ±10%	10	31	5.8 / 8.2	81.3 / 73.3
Nitrate (as N) ¹¹	27 ±10%	10	30.2	5.5 / 7.9	79.6 / 73.4
Nitrite (as N) ¹¹	3.0 ±10%	1.0	3.1	0.27 / 0.42	90.1 / 86.1
Radium 226/228 ²	25 pCi/L ⁵ ±10%	5 pCi/L ⁵	25 pCi/L ⁵	5 / 5 pCi/L ⁵	80 / 80 pCi/L ⁵
Selenium ²	0.10 ±10%	0.05	0.099	0.002 / 0.003	98.3 / 97.0
Turbidity ²	11 ±1 NTU ⁶	0.5 NTU ⁶	11 NTU ⁶	0.1 / 0.2 NTU ⁶	99.1 / 98.0
TDS ²	750 ±40	187	770	50 / 73	93.4 / 90.5
Chlorine Taste & Odor	2.0 ±10%	1.0	1.9	0.09 / 0.19	95.2 / 90.5
Ammonium ⁷	1.2 ±10%	1.0 ⁸	2.5	0.24	90
Bicarbonate ⁷	300 ±10%	100 ⁸	280	10	96
Bromide ⁷	1.5 ±10%	3.3 ⁸	11	1.3	89
Chloride ⁷	800 ±10%	250 ⁸	770	60	92
Magnesium ⁷	30 ±10%	10 ⁸	31	<1.0	97
Sodium ⁷	350 ±10%	117 ⁸	340	40	88
Sulfate ⁷	800 ±10%	250 ⁸	780	12	98
Tannin ⁷	3.0 ±10%	1.0 ⁸	2.9	0.1	97
Zinc ⁷	15 ±10%	5.0 ⁸	15	0.25	98

Daily Production Rate Model ECOP30: 14.76 gal./day (55.9 liters/day)²

Efficiency Rating Model ECOP30: 10.63%⁹

Recovery Rating Model ECOP30: 21.18%¹⁰

Chlorine Reduction Capacity Model ECOP30: 3,850 gallons (14,574 liters)

¹ Milligrams per liter, which is equivalent to parts per million (PPM).

² Tested by NSF International according to NSF/ANSI Standard 58.

³ NSF minimum percent reduction requirement. Acceptance level for this substance is based on percent reduction, rather than maximum effluent concentration.

⁴ Particles per milliliter.

⁵ Pico Curies per liter.

⁶ Nephelometric Turbidity Units.

⁷ Tested by Spectrum Labs, a qualified independent laboratory, against accepted industry protocol.

⁸ There is no maximum permissible effluent concentration for this substance because it is not included in the chemical reduction claims listed in NSF Standard 58. The maximum effluent concentrations listed were established by Spectrum Labs and are based on one third of the target influent.

⁹ Efficiency rating means the percentage of the influent water to the system that is available to the user as reverse osmosis treated water under operating conditions that approximate daily usage.

¹⁰ Recovery rating means the percentage of the influent water to the membrane portion of the system that is available to the user as reverse osmosis treated water when the system is operated without a storage tank or when the storage tank is by-passed.

¹¹ Certified by IAPMO R&T.

Performance Data

ARSENIC FACTS

Background

Arsenic (abbreviated As) can occur naturally in well water. There are two forms of arsenic: pentavalent arsenic [also called As (V), As (+5), and arsenate] and trivalent arsenic [also called As (III), As (+3), and arsenite]. Although both forms are potentially harmful to human health, trivalent arsenic is considered more harmful than pentavalent arsenic. In well water, arsenic may be pentavalent, trivalent, or a combination of both. Additional information about arsenic in water can be found on the Internet at the U.S. Environmental Protection Agency (USEPA) website: www.epa.gov/safewater/arsenic.html.

Testing Your Water

Arsenic in water has no color, taste or odor. It must be measured by a lab test. Public water utilities must have their water tested for arsenic. You can get the results from your water utility. If you have your own well, you can have the water tested. The local health department or the state environmental health agency can provide a list of certified labs. The cost is typically \$15 to \$30.

Pentavalent vs. Trivalent Arsenic Removal

These systems are very effective at reducing pentavalent arsenic from drinking water. These models were tested in a lab and proven to reduce 300 parts per billion (ppb) pentavalent arsenic to below 10 ppb, the USEPA standard for safe drinking water.

RO systems are not as effective at reducing trivalent arsenic from water. These models will not convert trivalent arsenic to pentavalent arsenic. If you have free chlorine residual in contact with your water supply for at least one minute any trivalent arsenic will be converted to pentavalent arsenic and reduced by this RO. Other water treatment chemicals such as ozone, and potassium permanganate will also change trivalent arsenic to pentavalent arsenic. A combined chlorine residual (also called chloramine) may not convert all the trivalent arsenic. If you get your water from a public water utility, contact the utility to find out if free chlorine or combined chlorine is used in the water system.

Maintenance

It is strongly recommended that you follow the maintenance instructions and have your water tested periodically to make sure the system is performing properly. See replacement element information above for recommendations on maintaining your Reverse Osmosis drinking water treatment system.