

# ECOPURE®

Water Solved.®

## Model ECOP20

How to install, operate  
and maintain your Undersink  
Drinking Water System

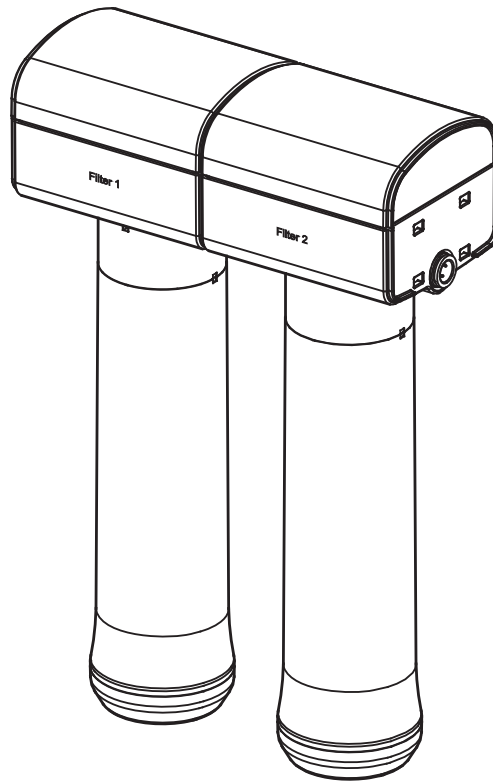

### PRODUCT REGISTRATION AND WARRANTY EXTENSION

Please register your product on  
[www.ecopure.com](http://www.ecopure.com)

See warranty page for  
extended warranty details.



If you have any questions or concerns when  
installing, operating or maintaining your water  
filtration system, call our toll free number:

**1-800-693-1138**

or visit **[www.ecopure.com](http://www.ecopure.com)**

When you call, please be prepared to provide  
the model number and date code of  
your product, found inside the top cover.

System tested and certified by NSF International  
against NSF/ANSI Standards 42 & 53. See  
performance data on pages 12 & 13 for details.  
System tested and certified to CSA B483.1 and  
NSF/ANSI/CAN 372.



Manufactured and warranted by  
Water Channel Partners  
1890 Woodlane Drive  
Woodbury, MN 55125

7400015 (Rev. B 4/17/24)

*Installation and Operation Manual*

---

# Table of Contents

	<u>Page</u>
Before You Start / Specifications & Dimensions . . . . .	3
Parts of the System / Materials and Tools Needed / Typical Undersink Installation . . . . .	4
Installation Steps . . . . .	5-7
Filter Cartridge Life / Filter Cartridge Replacement . . . . .	8
Troubleshooting the System . . . . .	9
Repair Parts . . . . .	10
Warranty . . . . .	11
Performance Data . . . . .	12-13

---

## Before You Start

- ▼ Read all steps and guides carefully before installing and using your undersink drinking water filter system. Follow all steps exactly to correctly install. Reading this manual will also help you to get all the benefits from the undersink drinking water filter system.
- ▼ Do not use with water that is microbiologically unsafe or of unknown quality without adequate disinfection before or after the system. This system is certified for cyst reduction and may be used on disinfected waters that may contain filterable cysts.
- ▼ All plumbing should be done in accordance with local codes and requirements. In Massachusetts, plumbing code 248 CMR 3.00 and 10.00 shall be adhered to. Consult with your licensed plumber.
- ▼ The undersink drinking water filter system works on water pressures of 30 psi (minimum) to 100 psi (maximum). If your house water pressure is over the maximum, install a pressure reducing valve in the water supply pipe to the filter system.
- ▼ Do not install the undersink drinking water filter system outside, or in extreme hot or cold temperatures. Temperature of the water supply to the undersink drinking water filter system must be between 40°F and 100°F. Do not install on hot water.

## Specifications and Dimensions

Min. - Max. Supply Water Pressure	30 - 100 psi (207 - 689 kPa)
Min. - Max. Supply Water Temperature	40 - 100 °F (4 - 38 °C)
Inlet - Outlet	3/8" quick connect fittings and tubing included

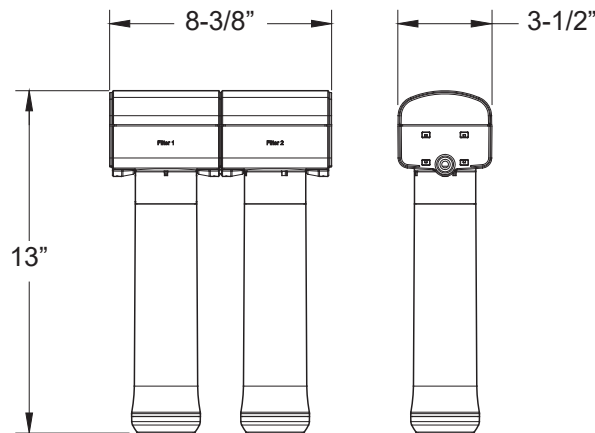

Questions? Call toll free: 1-800-693-1138

# Parts of the System

- filter system assembly
- water supply fitting
- filtered water faucet for sink or countertop mounting
- 3/8" tubing to make all needed connections

## Materials and Tools Needed

**NOTE:** Gather the required tools before starting installation. Read and follow the instructions provided with any tools listed here.

- slotted and Phillips screwdrivers
- pliers and adjustable jaw wrench
- tubing cutter
- electric drill and 1-1/4" drill bit if mounting hole is needed for the faucet

**IMPORTANT:** To avoid damaging the sink, consult a qualified plumber or installer for drilling procedures in porcelain or stainless steel.

## Typical Undersink Installation

Locate the water filter housing on the cold water supply pipe, under the kitchen and/or bathroom sink, to filter the cold drinking water. Refer to the following drawing.

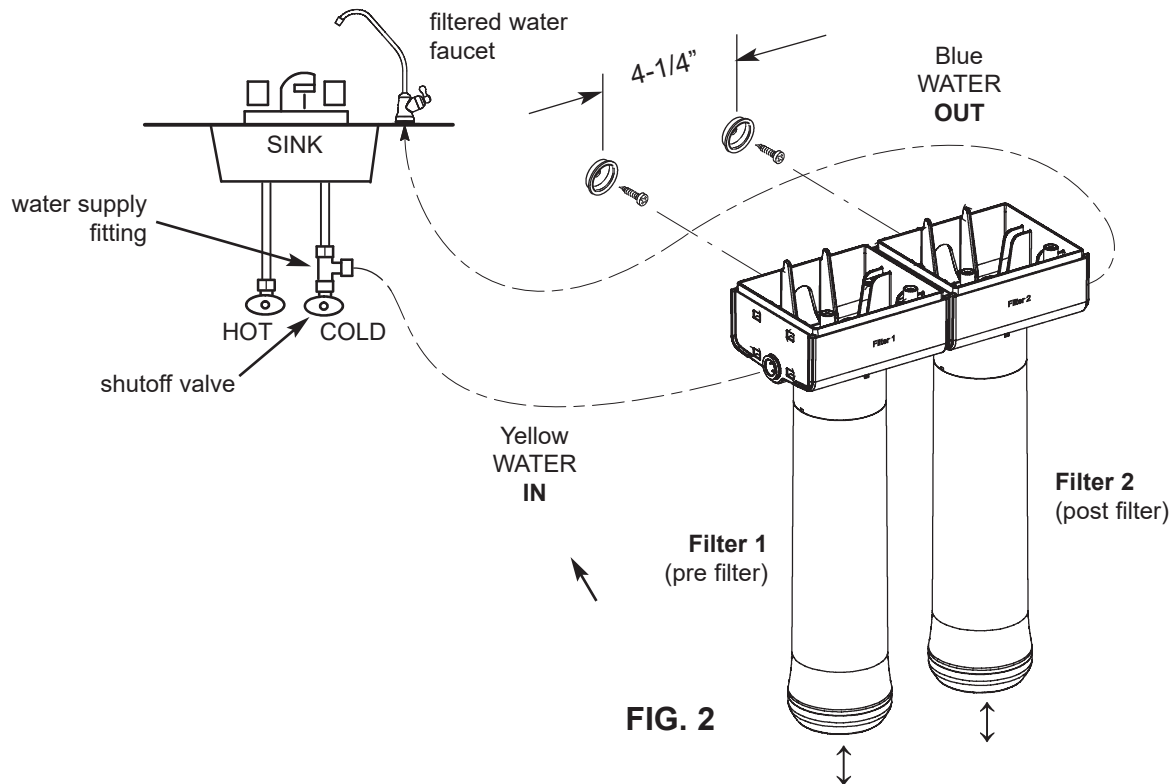

Fig. 1

**NOTE:** Be sure to allow a minimum space of 1-1/2" under the system for removing the filter cartridges, in order to change the cartridges.

Questions? Call toll free: 1-800-693-1138

# Installation Steps

## Step 1 - Cold Water Supply Fitting

Check and comply with local plumbing codes as you plan, then install a cold water supply fitting. The fitting must provide a leak-tight connection to the water filter 3/8" tubing. A typical connection using the included water supply fitting is shown in Figure 2A. An optional connection using standard plumbing fittings (not included) is shown in Figure 2B.

### Included Water Supply Fitting

1. Close the cold water shutoff valve (angle stop valve) that the water supply fitting will be installed on, and open faucet(s) to relieve pressure.
2. Disconnect the existing cold water line from the water shutoff valve.
3. Make sure that the water supply fitting's gasket is inside the female threaded portion of the fitting.
4. Install the water supply fitting onto the cold water shutoff valve, where the existing cold water line was removed, and hand tighten. Be careful not to cross thread or overtighten.
5. Connect the existing cold water line to the male threaded portion of the water supply fitting and hand tighten. Be careful not to cross thread or overtighten.

### Optional Pipe Fittings (compression type shown)

**NOTE:** Be sure to turn off the water supply and open a faucet to drain the pipe.

Complying with plumbing codes, install a fitting on the cold water pipe to adapt 3/8" OD tubing. A typical connection is shown in Figure 2B. If threaded fittings are used, be sure to use pipe joint compound or thread sealing tape on outside threads.

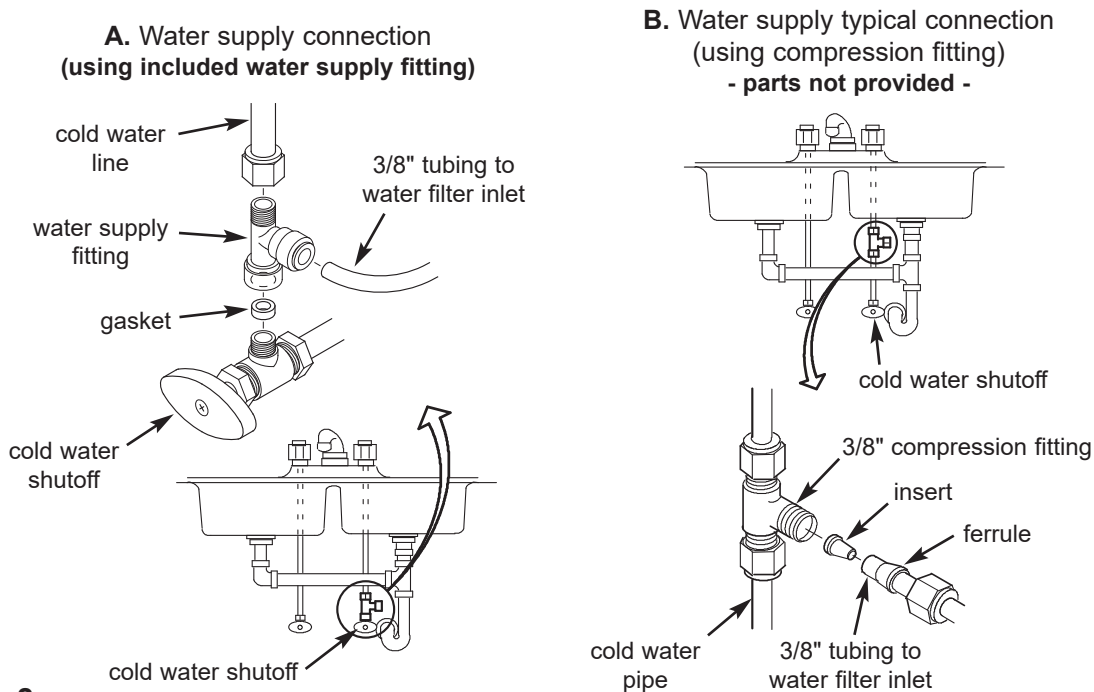

Fig. 2

---

# Installation Steps

## Step 2 - Make Hole For Filtered Water Faucet

**IMPORTANT:** To avoid damaging the sink, consult a qualified plumber or installer for drilling procedures in porcelain or stainless steel. Special drill bits are made for this.

1. Select one of the following places to install the faucet. Be sure there's room underneath so you can make the needed connections.

- In an existing sink spray attachment hole.
- Drill a hole in the sink top.
- Drill a hole in the countertop next to the sink.

2. If drilling is needed make a 1-1/4" dia. (minimum) hole for the faucet.

## Step 3 - Install Faucet

1. Mount faucet base to sink hole until the faucet base is flat against the sink surface. The rubber gasket should be between the sink surface and the faucet base. See Figure 3.

2. Tighten the toggle bolts until the base is firmly mounted to the sink surface. Do not overtighten.

3. Feed a length of 3/8" blue tubing up through the hole and insert end into the push-in fitting on the bottom of the faucet. Push tubing through the collet and all the way into the fitting. Full engagement is 3/4" length of tube into the fitting. Pull on the tube to be sure it's held firmly in the fitting. The other end of this tubing will be connected to the filter system outlet on the next page.

4. Mount the faucet body on to the faucet base, 1/4 turn. See Figure 3.

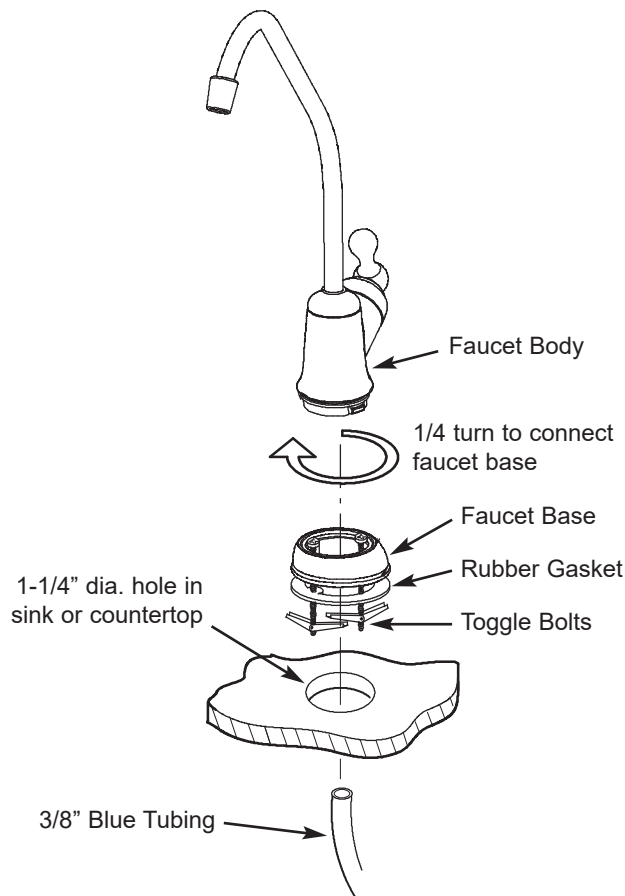

**Fig. 3**

Questions? Call toll free: 1-800-693-1138

# Installation Steps

## Step 4 - Make Tubing Connections

**NOTE: Remove protective foam plugs before connecting tubes (See Fig. 4). Discard foam plugs.**

1. Allowing some slack, measure and cut a length of 3/8" tubing to connect between the supply fitting and the filter system inlet, Figure 1. Cut the ends of the tubing square.
2. Insert tubing all the way into the supply fitting and inlet fitting. Pull on the tubing to be sure that it's held firmly in the fittings.
3. Repeat steps 1 and 2 to connect tubing from the faucet to the filter system outlet, Figure 1.

Tubing Connection (all push-in fitting locations):

This system includes push-in fittings for quick tubing connections. If working with the fittings, do the following.

### Connect Tubing:

1. Use a sharp cutter or knife to cut the end of tubing square.
2. Inspect the end (about 1") of the tubing to be sure there are no nicks, scratches or other rough spots. If needed cut the tubing again.
3. Push tubing through the collet and all the way into fitting. Full engagement is 3/4" length of tube into the fitting.

If tubing other than supplied with the system is used, be sure it is of high quality, exact size and roundness with a smooth surface.

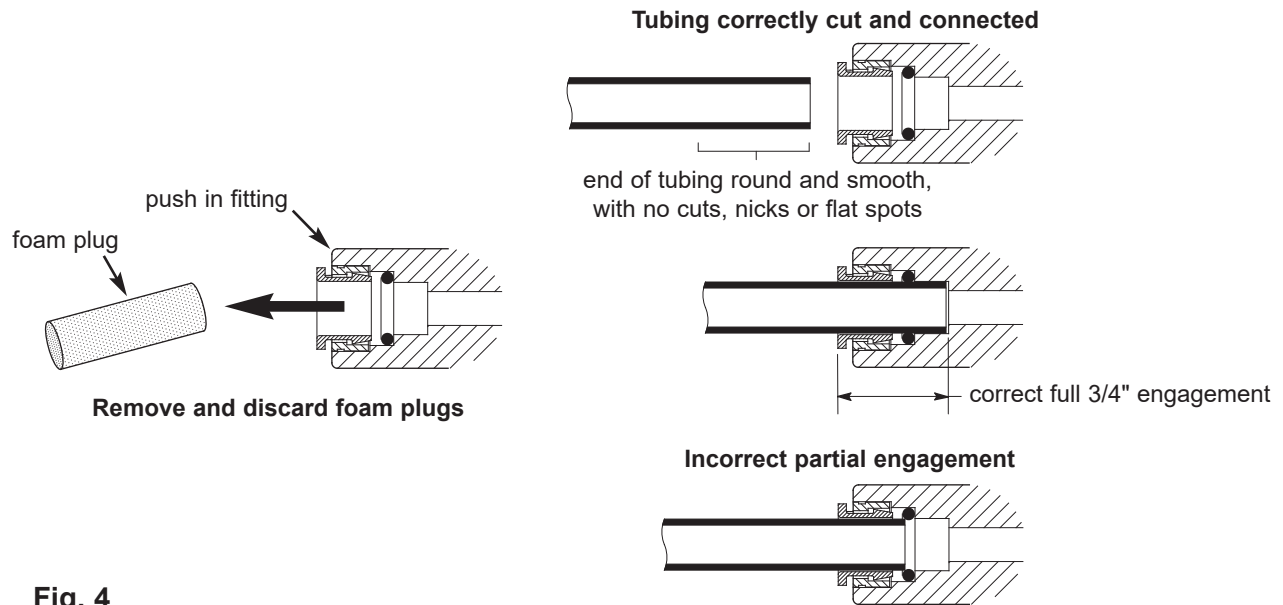

Fig. 4

### To Disconnect Tubing:

1. Push the collet inward and hold with a finger while pulling the tubing out.

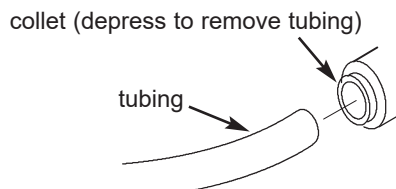

Fig. 5

Questions? Call toll free: 1-800-693-1138

---

# Filter Cartridges

## Filter Cartridge Life

**Taste and Odor Cartridges:** A taste and odor cartridge contains activated carbon, a black powder. When new, open the filtered water faucet and allow fine, carbon particles to purge from the cartridge. Close the faucet when you no longer see the “fines” (carbon particulates) in the filtered water, or approximately 10 minutes. It is recommended to replace the filter cartridges every six months of use. There are several variables that determine how long a cartridge will last. These include:

1. How much water you use, and
2. How much sediment, taste and/or odor, or other unwanted substance, is in the water.

Use the following information as a guide. However, no matter which type of cartridge you are using, you will know it is time to replace it when you first notice the return of the unwanted substance in your water.

Ecopure Undersink Drinking Water Filter system model ECOP20 with replacement element pack ECODWF conforms to NSF/ANSI 42 and 53 for the specific performance claims as verified and substantiated by test data. The rated capacity for this system is 270 gallons (1022 liters) at a rated service flow of 0.5 gpm (gallons per minute).

## Filter Cartridge Replacement

1. Turn filter cartridge to the left to remove cartridges from the filter heads.
2. Dispose of the cartridges in a proper manner.
3. Install new cartridges. Turn cartridges to the right to re-attach to the filter heads.

**Taste and Odor Cartridges:** A taste and odor cartridge contains activated carbon, a black powder. When new, open the filtered water faucet and allow the fine carbon particles to purge from the cartridge. Close the faucet when you no longer see the “fines” in the filtered water, or approximately 10 minutes.

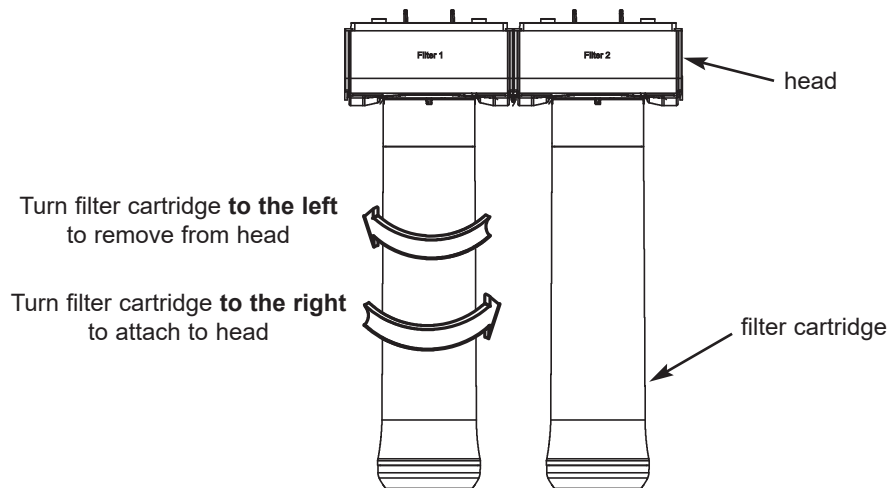

Fig. 6



---

## Troubleshooting the System

<b>Problem: Taste and/or Odor.</b>	
<b>Cause:</b> Filter 1 and 2 expended.	<b>Correction:</b> Replace the filter cartridges.
<b>Cause:</b> System contaminated.	<b>Correction:</b> Sanitize system. Call 1-800-693-1138 for instructions.
<b>Problem: Water leaks at push connect fittings.</b>	
<b>Cause:</b> Tubing not pushed in all the way.	<b>Correction:</b> Push tubing in all the way into fittings.
<b>Cause:</b> Tubing not cut square.	<b>Correction:</b> Cut tubing square.
<b>Cause:</b> Tubing nicked.	<b>Correction:</b> Remove nicked portion, reinsert tubing into fitting.
<b>Cause:</b> Outer tubing surface not smooth.	<b>Correction:</b> Remove rough portion, reinsert tubing into fitting.

# Repair Parts List

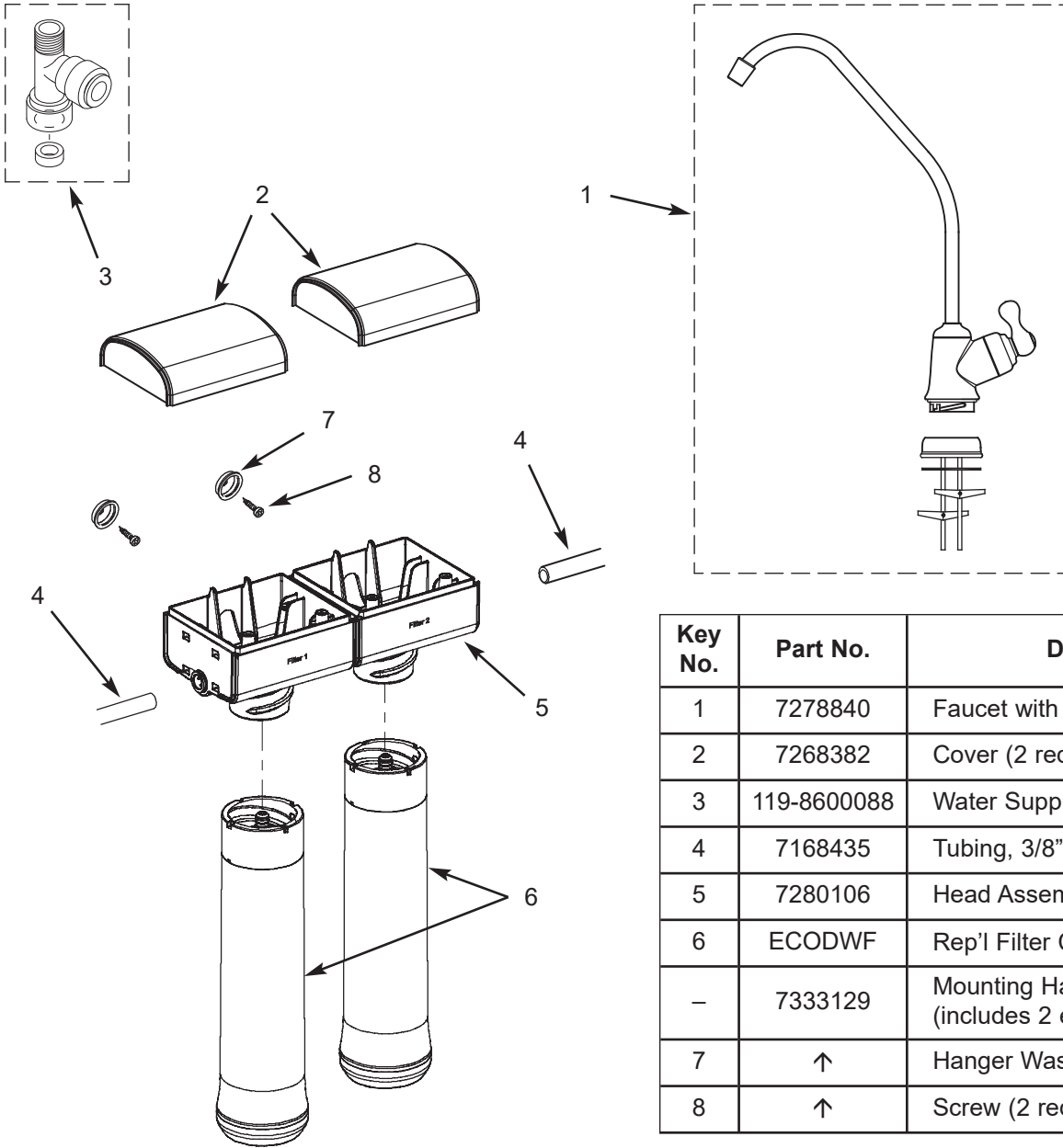

Key No.	Part No.	Description
1	7278840	Faucet with Base, Chrome
2	7268382	Cover (2 req'd)
3	119-8600088	Water Supply Fitting, 3/8" Q.C.
4	7168435	Tubing, 3/8" x 72" long, White
5	7280106	Head Assembly
6	ECODWF	Rep'l Filter Cartridge (2 pack) *
-	7333129	Mounting Hardware Kit (includes 2 ea. of Key Nos. 7 & 8)
7	↑	Hanger Washer (2 req'd)
8	↑	Screw (2 req'd)

\* Please purchase replacement cartridges from the retailer where you bought your drinking water system.

For repair parts call 1-800-693-1138.

Questions? Call toll free: 1-800-693-1138

## EXTEND YOUR WARRANTY:

You can turn your water filtration system's one year factory warranty into a lifetime warranty by saving your receipts for purchases of EcoPure replacement filter cartridges. See "Lifetime Warranty" below for details.

### WARRANTY

#### UNDERSINK DRINKING WATER FILTRATION SYSTEM - MODEL ECOP20 (not including filter cartridges)

**Warrantor: Water Channel Partners, 1890 Woodlane Drive, Woodbury, MN 55125**

##### One Year Warranty:

Warrantor guarantees, to the original purchaser when the product is purchased from an authorized dealer, and when installed and maintained in accordance with the instructions, that the Undersink Drinking Water Filtration System (ECOP20) will be free from defects in materials and workmanship and will perform in accordance with its written specifications for a period of one (1) year from the date the product is delivered.

##### Lifetime Warranty:

Warrantor guarantees, to the original purchaser only, that the Undersink Drinking Water Filtration System (ECOP20) will be free from defects in materials and workmanship and will perform in accordance with its written specifications for the lifetime of the purchaser, provided that:

- The product is purchased from an authorized dealer.
- The system is installed and maintained in accordance with the instructions in the same home where it was originally installed.
- The purchaser replaces both the pre and post filters every six (6) months and saves their receipts, for proof of purchase of the EcoPure ECODWF filter cartridge set, in case a warranty claim is made. Purchase of no more than two (2) ECODWF filter sets in a 12 month period may be applied toward compliance with this warranty.

Failure to adhere to the above requirements from the date the product is delivered voids the lifetime warranty.

If, during such respective period, a part proves, after inspection, to be defective, Warrantor will, at its sole option, either replace or repair the part without charge except normal shipping and installation charges. If a repair or replacement part is unavailable, Warrantor may refund the original purchase price. Labor to maintain the equipment is not part of the warranty. Filter cartridges, which are expendable, are not covered by the warranty.

If you have questions regarding a warranted product, need assistance with installation or troubleshooting, wish to order a part or report a warranty issue, we are just a phone call away. SIMPLY DIAL 1-800-693-1138 for assistance.

##### General Provisions

The above warranties are effective provided the Undersink Drinking Water Filtration System is operated at water pressures not exceeding 100 psi (7.0 kg/cm<sup>2</sup>), and at water temperatures not exceeding 100°F (38°C); provided further that the Undersink Drinking Water Filtration System is not subject to abuse, misuse, alteration, neglect, freezing, accident or negligence; and provided further that the Undersink Drinking Water Filtration System is not damaged as the result of any force of nature such as, but not limited to, flood, hurricane, tornado or earthquake.

The limited warranty does not cover damage due to: (a) transportation, (b) storage, (c) improper use, (d) failure to follow the product instructions or to perform any preventive maintenance, (e) modifications, (f) unauthorized repair, (g) normal wear and tear, or (h) external causes such as accidents, abuse, or other actions or events beyond Warrantor's reasonable control. Use of aftermarket, used, or non-manufacturer provided parts will void all warranties. Warranty does not cover failures due to improper product installation. Warrantor is excused if failure to perform its warranty obligations is the result of strikes, government regulation, materials shortages, or other circumstances beyond its control.

THERE ARE NO WARRANTIES ON THE UNDERSINK DRINKING WATER FILTRATION SYSTEM BEYOND THOSE SPECIFICALLY DESCRIBED ABOVE. ALL IMPLIED WARRANTIES, INCLUDING ANY IMPLIED WARRANTY OF MERCHANTABILITY OR OF FITNESS FOR A PARTICULAR PURPOSE, ARE DISCLAIMED TO THE EXTENT THEY MIGHT EXTEND BEYOND THE ABOVE PERIODS. THE SOLE OBLIGATION OF WARRANTOR UNDER THESE WARRANTIES IS TO REPLACE OR REPAIR THE COMPONENT OR PART WHICH PROVES TO BE DEFECTIVE WITHIN THE SPECIFIED TIME PERIOD, AND WARRANTOR IS NOT LIABLE FOR CONSEQUENTIAL OR INCIDENTAL DAMAGES. NO DEALER, AGENT, REPRESENTATIVE, OR OTHER PERSON IS AUTHORIZED TO EXTEND OR EXPAND THE WARRANTIES EXPRESSLY DESCRIBED ABOVE.

Some states do not allow the exclusion or limitation of incidental or consequential damages, so the above limitation or exclusion may not apply to you. This warranty gives you specific legal rights, and you may have other rights which vary from state to state. This warranty applies to consumer-owned installations only.

# Performance Data



## Model ECOP20 Drinking Water Filter

**IMPORTANT NOTICE:** Read this performance data and compare the capabilities of this unit with your actual water treatment needs. It is recom-

mended that, before purchasing a water treatment unit, you have your water supply tested to determine your actual water treatment needs. This filter system is designed to be used for the reduction of the performance claims listed below. Do not use where water is microbiologically unsafe or of unknown quality, without adequate disinfection before or after the system. Systems certified for cyst reduction may be used on disinfected water that may contain filterable cysts. While testing was performed under standard laboratory conditions, actual performance of this system may vary based on local water conditions. Some or all of the contaminants reduced by this unit may not be in your water supply. See elsewhere in this owner's manual for further instructions on filter cartridge replacement, system installation, operating procedures, and warranty. The maintenance instructions must be followed for the product to perform as indicated below.

### General Information

This filter improves the taste and odor and reduces many chemical contaminants in drinking water. This system has been tested according to NSF/ANSI 42 and 53 for reduction of the substances listed below. The concentration of the indicated substances in water entering the system was reduced to a concentration less than or equal to the permissible limit for water leaving the system, as specified in NSF/ANSI 42 and 53. The testing was performed using spiked tap water at a flow rate of 0.5 gpm (1.9 L/min.), pH of 7.5 ± 0.5, pressure of 60 psig, and temperature of 68 ± 5°F.

### Installation Requirements

Pressure Range ..... 30-100 psig (207-689 kPa)  
 Temperature Range ..... 40-100°F (5-38°C)  
 Service Flow Rate ..... 0.5 gpm (1.9 L/min.)  
 Service Life ..... 270 Gallons (1,022 Liters)

### Maintenance

Cartridges should be replaced every 270 gallons or six months, whichever comes first. Replacement filter prices will vary. Estimated costs of replacement filter elements (part number ECODWF) range from \$30.00 to \$50.00 per filter element.

### PERFORMANCE CLAIMS

Contaminant	NSF Required Influent Level (mg/L) <sup>2</sup>	NSF Max. Permissible Eff. Level (mg/L) <sup>2</sup>	Average Influent Level (mg/L) <sup>2</sup>	Avg. / Max. Effluent (mg/L) <sup>2</sup>	Avg. / Min. Percent Reduction	EPA MCL <sup>1</sup> (mg/L) <sup>2</sup>
Cyst	≥50,000 particles/mL <sup>4,5</sup>	99.95% <sup>3</sup>	93,000 particles/mL <sup>4</sup>	<1 / <4 particles/mL <sup>4</sup>	99.99 / 99.99	None <sup>7</sup>
Lead @ pH 6.5	0.15 ±10%	0.010	0.152	0.001 / 0.001	98.8 / 93.1	0.015
Lead @ pH 8.5	0.15 ±10%	0.010	0.150	0.001 / 0.001	99.3 / 99.3	0.015
Methyl <i>tert</i> -Butyl Ether (MTBE)	0.015 ±20%	0.005	0.01467	0.0005 / 0.0005	96.2 / 96.2	None <sup>6</sup>
<b>Substance</b>						
Chlorine Taste & Odor	2.0 ±10%	50% <sup>3</sup>	2.0	0.05 / 0.08	97.5 / 96.5	None <sup>6</sup>
<b>VOC Reduction<sup>7</sup></b>						
Chloroform	0.30 ±10%	95% <sup>3</sup>	0.320	0.0005 / 0.0005	99.8 / 99.8	0.080

<sup>1</sup> Environmental Protection Agency Maximum Contaminant Level, as required under the Safe Drinking Water Act.

<sup>2</sup> Milligrams per Liter, which is equivalent to parts per million (PPM).

<sup>3</sup> NSF minimum percent reduction requirement. Acceptance level for this substance is based on percent reduction, rather than maximum effluent concentration.

<sup>4</sup> Cyst reported in particles per milliliter.

<sup>5</sup> Microspheres was used as a surrogate.

<sup>6</sup> The EPA has not determined an MCL for this chemical.

<sup>7</sup> Chloroform was used as a surrogate for the reduction of chemicals specified in the Organic Chemicals Reduced by Chloroform Surrogate Testing table.

# Performance Data

## ORGANIC CHEMICALS REDUCED BY CHLOROFORM SURROGATE TESTING

Contaminant	Avg. <sup>1</sup> Influent (µg/L) <sup>3</sup>	Maximum Effluent (µg/L) <sup>3</sup>	Percent Removal	EPA MCL <sup>2</sup> (µg/L) <sup>3</sup>	Contaminant	Avg. <sup>1</sup> Influent (µg/L) <sup>3</sup>	Maximum Effluent (µg/L) <sup>3</sup>	Percent Removal	EPA MCL <sup>2</sup> (µg/L) <sup>3</sup>
Alachlor	50	1.0 <sup>4</sup>	>98	2.0	Haloketones (HK):				NA
Atrazine	100	3.0 <sup>4</sup>	>97	3.0	1,1-Dichloro-2-Propanone	7.2	0.1 <sup>5</sup>	99	NA
Benzene	81	1.0 <sup>4</sup>	99	5.0	1,1,1-Trichloro-2-Propanone	8.2 <sup>6</sup>	0.3 <sup>5</sup>	96	NA
Carbofuran	190	1.0 <sup>4</sup>	>99	40	Heptachlor	25	0.01 <sup>4</sup>	>99	0.4
Carbon Tetrachloride	78	1.8 <sup>5</sup>	98	5.0	Heptachlor Epoxide	10.7 <sup>7</sup>	0.2 <sup>7</sup>	98	0.2
Chlorobenzene	77	1.0 <sup>4</sup>	99	100	Hexachlorobutadiene	44	1.0 <sup>4</sup>	98	NA
Chloropicrin	15	0.2 <sup>5</sup>	99	NA	Hexachlorocyclopentadinene	60	0.002 <sup>4</sup>	>99	50
2,4-D	110	1.7 <sup>5</sup>	98	70	Lindane	55	0.01 <sup>4</sup>	>99	0.2
Dibromochloropropane (DBCP)	52	0.02 <sup>4</sup>	>99	0.2	Methoxychlor	50	0.1 <sup>4</sup>	>99	40
o-Dichlorobenzene	80	1.0 <sup>4</sup>	99	600	Pentachlorophenol	96	1.0 <sup>4</sup>	99	1.0
p-Dichlorobenzene	40	1.0 <sup>4</sup>	98	75	Simazine	120	4.0 <sup>4</sup>	97	4.0
1,2-Dichloroethane	88	4.8 <sup>6</sup>	95 <sup>6</sup>	5.0	Styrene	150	0.5 <sup>4</sup>	>99	100
1,1-Dichloroethylene	83	1.0 <sup>4</sup>	99	7.0	1,1,2,2-Tetrachloroethane	81	1.0 <sup>4</sup>	99	NA
cis-1,2-Dichloroethylene	170	0.5 <sup>4</sup>	>99	70	Tetrachloroethylene	81	1.0 <sup>4</sup>	99	5.0
trans-1,2-Dichloroethylene	86	1.0 <sup>4</sup>	99	100	Toluene	78	1.0 <sup>4</sup>	99	1,000
1-2-Dichloropropane	80	1.0 <sup>4</sup>	99	5.0	2,4,5-TP (silvex)	270	1.6 <sup>4</sup>	99	50
cis-1,3-Dichloropropylene	79	1.0 <sup>4</sup>	99	NA	Tribromoacetic acid	42	1.0 <sup>4</sup>	98	NA
Dinoseb	170	0.2 <sup>5</sup>	99	7.0	1,2,4-Trichlorobenzene	160	0.5 <sup>4</sup>	>99	70
Endrin	53	0.59 <sup>5</sup>	99	2.0	1,1,1-Trichloroethane	84	4.6 <sup>5</sup>	95	200
Ethylbenzene	88	1.0 <sup>4</sup>	99	700	1,1,2-Trichloroethane	150	0.5 <sup>4</sup>	>99	5.0
Ethylene Dibromide (EDB)	44	0.02 <sup>4</sup>	>99	0.05	Trichloroethylene	180	1.0 <sup>4</sup>	>99	5.0
Haloacetonitriles (HAN):				NA	Trihalomethanes (includes):	300	15	95	80
Bromochloroacetonitrile	22	0.5 <sup>5</sup>	98	NA	Chloroform (surrogate chemical)				
Dibromoacetonitrile	24	0.6 <sup>5</sup>	98	NA	Bromoform				
Dichloroacetonitrile	9.6	0.2 <sup>5</sup>	98	NA	Bromodichloromethane				
Trichloroacetonitrile	15	0.3 <sup>5</sup>	98	NA	Chlorodibromomethane				
					Xylenes (total)	70	1.0 <sup>4</sup>	99	10,000

<sup>1</sup> Influent challenge levels are average influent concentrations determined in surrogate qualification testing.

<sup>2</sup> Environmental Protection Agency Maximum Contaminant Level, as required under the Safe Drinking Water Act.

<sup>3</sup> Micrograms per Liter, which is equivalent to parts per billion (PPB).

<sup>4</sup> Maximum product water level was not observed, but was set at the detection limit of analysis.

<sup>5</sup> Maximum product water level is set at a value determined in surrogate qualification testing.

<sup>6</sup> Chemical reduction percent and maximum product water level calculated at chloroform 95% breakthrough point, as determined in surrogate qualification testing.

<sup>7</sup> The surrogate test results for Heptachlor Epoxide demonstrated a 98% reduction. These data were used to calculate an upper occurrence concentration, which would produce a maximum product water level at the MCL.