

# ECOPURE<sup>®</sup>

Water Solved.<sup>®</sup>

## Model EPHY

How to install, operate and maintain your Whole Home Water Treatment System

### PRODUCT REGISTRATION AND WARRANTY EXTENSION

Please register your product on [www.ecopure.com](http://www.ecopure.com)

See warranty page for extended warranty details.



If you have any questions or concerns when installing, operating or maintaining your water treatment system, call our toll free number:

**1-800-693-1138**

or visit **[www.ecopure.com](http://www.ecopure.com)**

When you call, please be prepared to provide the model and serial number of your product, found on the rating decal, located on the rim below the salt lid hinges.

System tested and certified by NSF International against NSF/ANSI Standard 42 for the reduction of chlorine taste and odor, and Standard 44 for hardness reduction, efficiency and the reduction of barium and radium 226/228, and certified to NSF/ANSI/CAN Standard 372.



System tested and certified by the Water Quality Association against CSA B483.1.



C US



# Installation and Operation Manual

Manufactured and warranted by  
Water Channel Partners  
1890 Woodlane Drive  
Woodbury, MN 55125

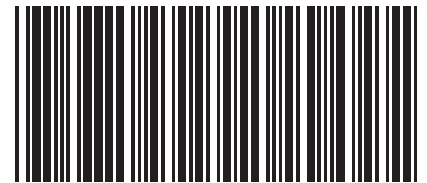

7388352 (Rev. E 10/20/23)

---

## TABLE OF CONTENTS

	<u>Page</u>
Specifications & Performance Claims .....	2-3
Dimensions .....	4
Safety Guides .....	4
Inspect Shipment .....	5
Water Treatment Information .....	5
Installation Requirements .....	6-7
Installation Instructions .....	8-11
Programming the Water Treatment System .....	12-14
Customizing Features / Options .....	15-17
Routine Maintenance .....	17-18
Troubleshooting .....	19-21
Exploded View & Parts List .....	22-25
Warranty .....	26

## Specifications & Performance Claims

This model is efficiency rated. The efficiency rating is valid only at the minimum salt dose. This system has a demand initiated regeneration (D.I.R.) feature that complies with specific performance specifications intended to minimize the amount of regenerant brine and water used in their operation.

This water treatment system has a rated softener efficiency of not less than 3,350 grains of total hardness exchange per pound of salt (based on sodium chloride) and shall not deliver more salt than its listed rating or be operated at a sustained maximum service flow rate greater than its listed rating. This system has been proven to deliver soft water for at least ten continuous minutes at the rated service flow rate. The rated salt efficiency is measured by laboratory tests described in NSF/ANSI Standard 44. These tests represent the maximum possible efficiency that the system can achieve. Operational efficiency is the actual efficiency after the system has been installed. It is typically less than the rated efficiency, due to individual application factors including water hardness, water usage, and other contaminants that reduce a softener's capacity.

While testing was performed under standard laboratory conditions, actual performance of the system may vary based on local water conditions. This system has been tested according to NSF/ANSI Standard 42 for the reduction of chlorine taste and odor. The concentration of the indicated substance in water entering the system was reduced to a concentration less than or equal to the permissible limit for water leaving the system, as specified in NSF/ANSI Standard 42.

continued on next page

# Specifications & Performance Claims

SPECIFICATIONS											
	Model EPHY										
Model Code	EPHY										
Rated Softening Capacity (Grains @ Salt Dose)	12,300 @ 2.9 lbs. (1.3 kg) 23,800 @ 9.2 lbs. (4.2 kg) 27,200 @ 15.0 lbs. (6.8 kg)										
Rated Efficiency (Grains/Pound of Salt @ Minimum Salt Dose)	4,395 @ 2.9 lbs. (1.3 kg)										
Water Used During Regeneration @ Minimum Salt Dose	5 gallons (18.9 liters) / 1,000 grains										
Total Water Used Per Regeneration @ Maximum Salt Dose	50.3 gallons (190 liters)										
Rated Service Flow Rate	6.5 gpm (24.6 lpm)										
Amount of High Capacity Ion Exchange Resin	0.94 cu. ft. (26.6 liters)										
Pressure Drop at Rated Service Flow	12.8 psig										
Water Supply Max. Hardness	95 gpg										
Water Supply Max. Clear Water Iron	3 ppm*										
Water Pressure Limits (min. / max.)	20 - 100 psi (1.4 - 7.0 kg/cm <sup>2</sup> )										
Water and Ambient Temperature Limits (min. / max.)	40 - 100 °F (5 - 38 °C)										
Minimum Water Supply Flow Rate	3 gpm (11.4 lpm)										
Maximum Drain Flow Rate	2 gpm (7.6 lpm)										
Rated Capacity at Chlorine Concentration** of:	<table border="0"> <tr> <td>0.50 ppm</td> <td>2,280,000 gal. (8,630,000 liters)§</td> </tr> <tr> <td>0.75 ppm</td> <td>1,520,000 gal. (5,750,000 liters)§</td> </tr> <tr> <td>1.0 ppm</td> <td>1,140,000 gal. (4,310,000 liters)§</td> </tr> <tr> <td>1.5 ppm</td> <td>760,000 gal. (2,870,000 liters)§</td> </tr> <tr> <td>2.0 ppm</td> <td>570,000 gal. (2,150,000 liters)</td> </tr> </table>	0.50 ppm	2,280,000 gal. (8,630,000 liters)§	0.75 ppm	1,520,000 gal. (5,750,000 liters)§	1.0 ppm	1,140,000 gal. (4,310,000 liters)§	1.5 ppm	760,000 gal. (2,870,000 liters)§	2.0 ppm	570,000 gal. (2,150,000 liters)
0.50 ppm	2,280,000 gal. (8,630,000 liters)§										
0.75 ppm	1,520,000 gal. (5,750,000 liters)§										
1.0 ppm	1,140,000 gal. (4,310,000 liters)§										
1.5 ppm	760,000 gal. (2,870,000 liters)§										
2.0 ppm	570,000 gal. (2,150,000 liters)										

\*Capacity to reduce clear water iron is substantiated by laboratory test data. State of Wisconsin requires additional treatment if water supply contains clear water iron exceeding 5 ppm.

\*\*Typical residential chlorine concentration is 0.5 to 1.0 ppm.

§ From independent laboratory test data.

This system conforms to NSF/ANSI Standards 42 & 44 for the specific performance claims as verified and substantiated by test data.

**Variable Salt Dose:** The salt dose is selected by the electronic controls at regeneration time based on the amount needed.

PERFORMANCE CLAIMS		
Contaminant	Influent Challenge Level	Maximum Allowable Product Water Level
Barium	10 ±10% mg/L	2.0 mg/L
Radium 226/228	25 pCi/L	5 pCi/L
Substance	Influent Challenge Level	Reduction Requirement
Chlorine	2.0 ±10% mg/L	50%

**Questions? Call Toll Free 1-800-693-1138** or visit [www.ecopure.com](http://www.ecopure.com)

When you call, please be prepared to provide the model and serial number, found on the rating decal, typically located on the rim below the salt lid hinges.

# Dimensions

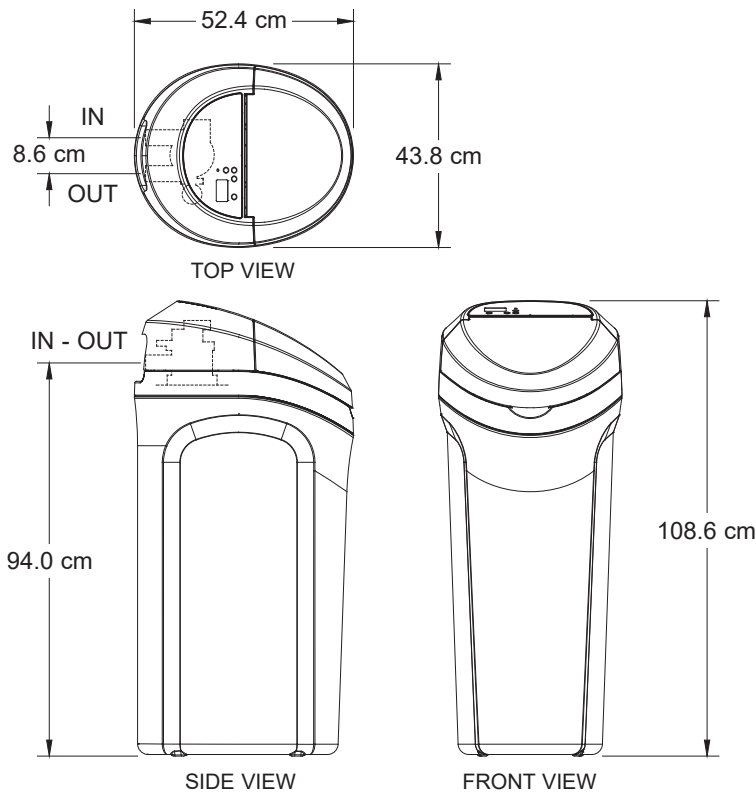

FIG. 1

## Safety Guides

- The water treatment system requires a minimum water flow of 3 gallons (11.4 L) per minute at the inlet. Maximum allowable inlet water pressure is 100 psi (7.0 kg/cm<sup>2</sup>). If your house water pressure is over the maximum, install a pressure reducing valve in the water supply pipe to the system (Adding a pressure reducing valve may reduce the flow). If your home is equipped with a back flow preventer, an expansion tank must be installed in accordance with local codes and laws.
- Temperature of the water supply to the softener must be 40-100°F (5-38°C). Do not install on hot water.
- The water treatment system works on 24V DC electrical power, supplied by a direct plug-in power supply (included). Be sure to use the included power supply and plug it into a nominal 120V, 60 Hz household outlet that is in a dry location only, grounded and properly protected by an overcurrent device such as a circuit breaker or fuse.
- Do not use this system to treat water that is microbiologically unsafe or of unknown quality without adequate disinfection upstream or downstream of the system.



European Directive 2002/96/EC requires all electrical and electronic equipment to be disposed of according to Waste Electrical and Electronic Equipment (WEEE) requirements. This directive or similar laws are in place nationally and can vary from region to region. Please refer to your state and local laws for proper disposal of this equipment.

### **Do not return the water treatment system to store.**

If you have any questions, or there are missing parts or damage, please call **Toll Free 1-800-693-1138** or visit **[www.ecopure.com](http://www.ecopure.com)**

When you call, please be prepared to provide the model and serial number, found on the rating decal, located on the rim below the salt lid hinges.

# Inspect Shipment

The parts required to assemble and install the water treatment system are included with the unit. Thoroughly check the water treatment system for possible shipping damage and parts loss. Also inspect and note any damage to the shipping carton.

Remove and discard (or recycle) all packing materials. To avoid loss of small parts, we suggest you keep the small parts in the parts bag until you are ready to use them.

## Packing List

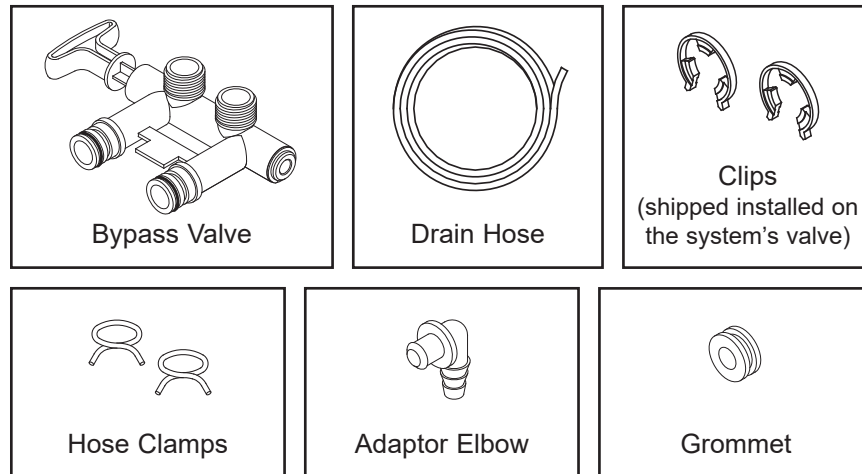

FIG. 2

## Water Treatment Information

### IRON

Iron in water can cause stains on clothing and plumbing fixtures. It can negatively affect the taste of food, drinking water, and other beverages. Iron in water is measured in parts per million (ppm). The total\* ppm of iron, and type or types\*, is determined by chemical analysis. Four different types of iron in water are:

- Ferrous (clear water) iron
- Ferric (red water) iron
- Bacterial and organically bound iron
- Colloidal and inorganically bound iron (ferrous or ferric)

Ferrous (clear water) iron is soluble and dissolves in water. This water treatment system will reduce moderate amounts of this type of iron (see specifications).\*\*

Ferrous (clear water) iron is usually detected by taking a sample of water in a clear bottle or glass.

Immediately after taking, the sample is clear. As the water sample stands, it gradually clouds and turns slightly yellow or brown as air oxidizes the iron. This usually occurs in 15 to 30 minutes.

When using the system to reduce Ferrous (clear water) iron, add 5 grains to the hardness setting for every 1 ppm of Ferrous (clear water) iron. See "Set Water Hardness Number" section.

Ferric (red water), and bacterial and organically bound irons are insoluble. This water treatment system will not remove ferric or bacterial iron. This iron is visible

immediately when drawn from a faucet because it has oxidized before reaching the home. It appears as small cloudy yellow, orange, or reddish suspended particles. After the water stands for a period of time, the particles settle to the bottom of the container. Generally these irons are removed from water by filtration. Chlorination is also recommended for bacterial iron.

Colloidal and inorganically bound iron is of ferric or ferrous form that will not filter or exchange out of water. This water treatment system will not remove colloidal iron. In some instances, treatment may improve colloidal iron water. Colloidal iron water usually has a yellow appearance when drawn. After standing for several hours, the color persists and the iron does not settle, but remains suspended in the water.

### SEDIMENT

Sediment is fine, foreign material particles suspended in water. This water treatment system will not remove sediment. This material is most often clay or silt. Extreme amounts of sediment may give the water a cloudy appearance. A sediment filter installed upstream of the system normally corrects this situation.

\* Water may contain one or more of the four types of iron and any combination of these. Total iron is the sum of the contents.

\*\* Capacity to reduce clear water iron is substantiated by laboratory test data.

# Installation Requirements

## LOCATION REQUIREMENTS

Consider all of the following when selecting an installation location for the water treatment system.

- Do not locate the water treatment system where freezing temperatures occur. Temperature of the water supply to the softener must be 40-100°F (5-38°C). Do not install on hot water. Freezing temperatures or hot water damage voids the warranty.
- To treat all water in the home, install the water treatment system close to the water supply inlet, and upstream of all other plumbing connections, except outside water pipes. Outside faucets should remain on hard water to avoid wasting treated water and salt.
- A nearby drain is needed to carry away regeneration discharge (drain) water. Use a floor drain, laundry tub, sump, standpipe, or other options (check your local codes). See "Air Gap Requirements" and "Valve Drain Requirements" sections.
- The water treatment system works on 24V DC electrical power, supplied by a direct plug-in power supply (included). Provide nearby a 120V, 60Hz electrical outlet in accordance with national and local codes.
- Always install the water treatment system between the water inlet and water heater. Any other installed water conditioning equipment should be installed between the water inlet and water treatment system (See Figure 4 below).
- Avoid installing in direct sunlight. Excessive sun heat may cause distortion or other damage to non-metallic parts.
- Install on a flat, stable surface that evenly supports the weight of the water softener.

## PLUMBING CODES

All plumbing must be completed in accordance with national, state and local plumbing codes.

## AIR GAP REQUIREMENTS

A drain is needed for regeneration water (See Figure 3). A floor drain, close to the water treatment system, is preferred. A laundry tub, standpipe, etc. are other drain options. Secure valve drain hose in place. Leave an air gap of 4 cm between the end of the hose and the drain. This gap is needed to prevent backflow of sewer water into the water treatment system. Do not put the end of the drain hose into the drain.

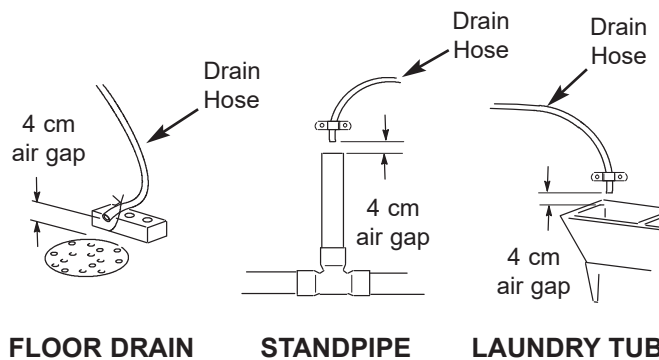

FIG. 3

## THE PROPER ORDER TO INSTALL WATER TREATMENT EQUIPMENT

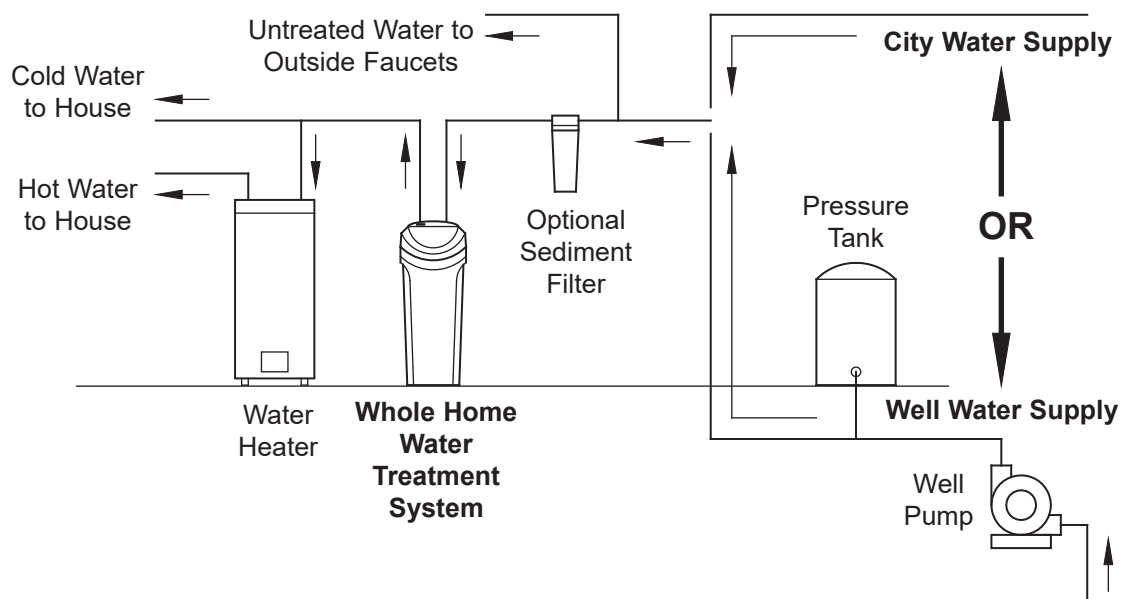

FIG. 4

# Installation Requirements

## VALVE DRAIN REQUIREMENTS

Using the flexible drain hose (included), measure and cut to the length needed. Flexible drain hose is not allowed in all localities (check your plumbing codes). If local codes do not allow use of a flexible drain hose, a rigid valve drain run must be used. Purchase a compression fitting (1/4 NPT x 1.25 cm minimum tube) and 1.25 cm tubing from your local hardware store. Plumb a rigid drain as needed (See Figure 6).

**NOTE:** Avoid drain hose runs longer than 9 meters.  
Avoid elevating the hose more than 2.5 meters above the floor. Make the valve drain line as short and direct as possible.

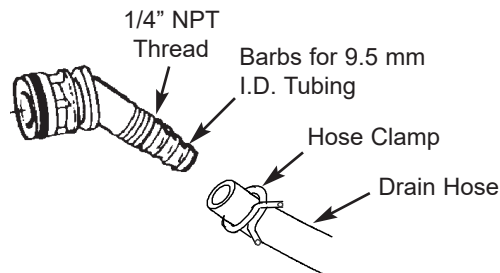

FIG. 5

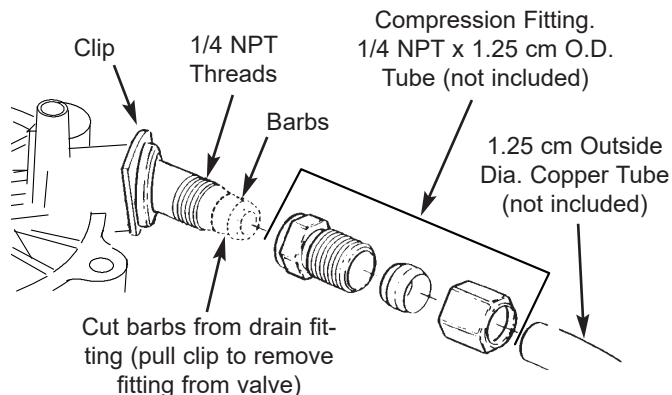

FIG. 6

## INLET / OUTLET PLUMBING OPTIONS

Always install either a single bypass valve (provided), as shown in Figure 7, or, if desired, parts for a 3 valve bypass system (not included) can be purchased and assembled, as shown in Figure 8. Bypass valves allow you to turn off water to the softener for maintenance if needed, but still have water in house pipes.

Use:

- Copper pipe
- Threaded pipe
- PEX (Crosslinked Polyethylene) pipe
- CPVC plastic pipe
- Other pipe approved for use with potable water

**IMPORTANT:** Do not solder with plumbing attached to the single bypass valve. Soldering heat will damage the plastic valve.

### SINGLE BYPASS VALVE

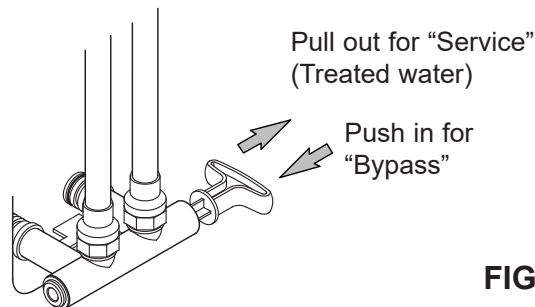

FIG. 7

### 3 VALVE BYPASS

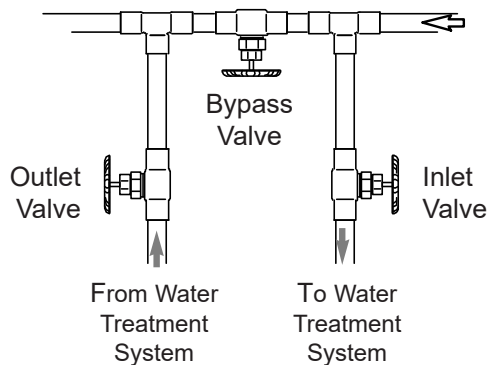
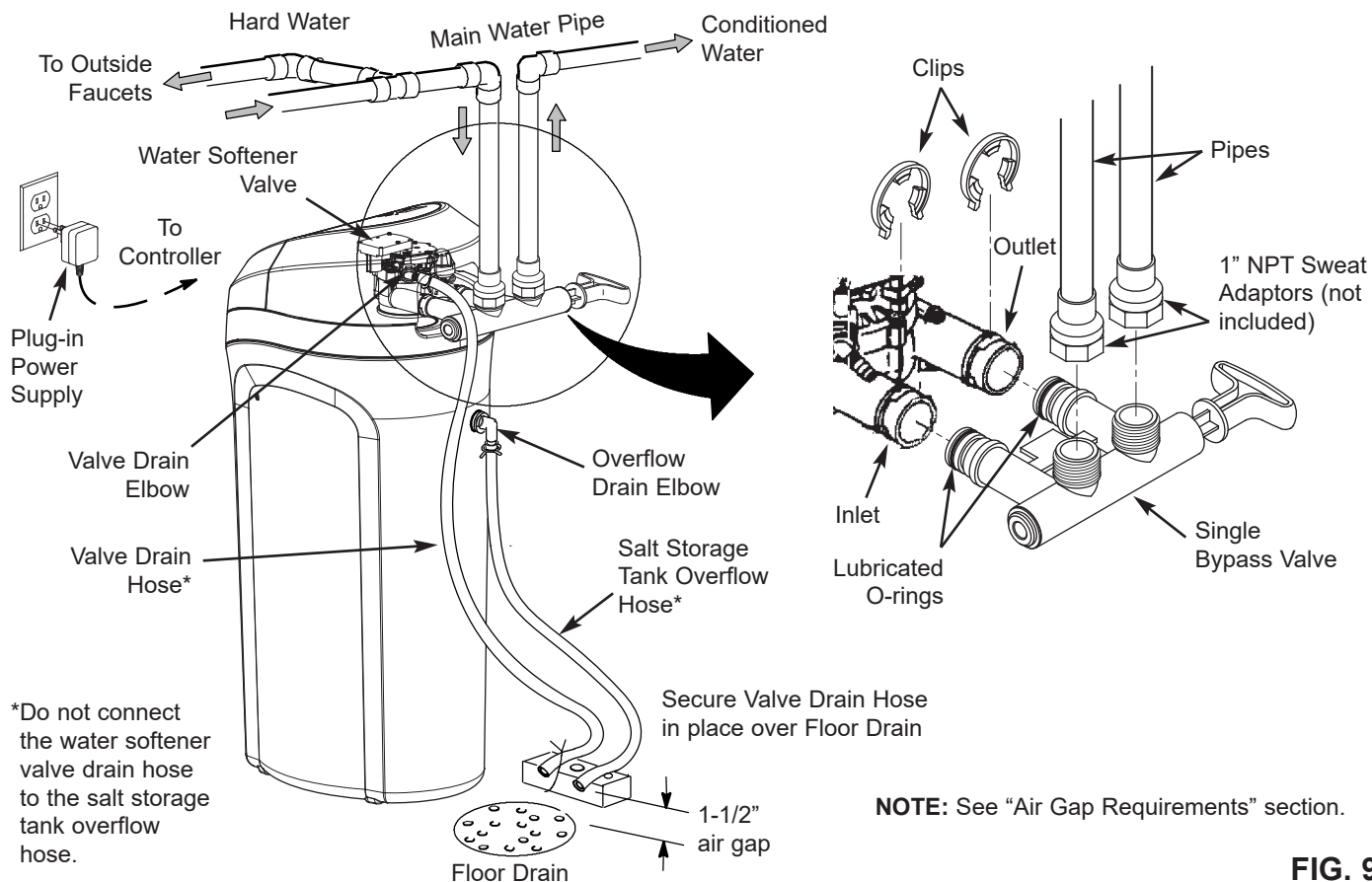

FIG. 8

# Installation Instructions

## Typical Installation



**FIG. 9**

### TURN OFF WATER SUPPLY

1. Close the main water supply valve, located near the well pump or water meter.
2. Shut off the electric or fuel supply to the water heater.
3. Open all faucets to drain all water from house pipes.

**NOTE:** Be sure not to drain water from the water heater, as damage to the water heater elements could result.

### ASSEMBLY

1. EcoPure models are factory assembled. During installation, unsnap and remove the top cover, together with the salt lid, to expose the water treatment system valve assembly. Set them aside to prevent damage. Check the brinewell to be sure it is secured and vertical (See Figure 13).
2. Install the brine tank overflow grommet and elbow into the 2 cm diameter hole in the back of the salt storage tank wall.

### MOVE THE SYSTEM INTO PLACE

1. Move the water treatment system into the desired location. Set it on a solid, level surface.

**IMPORTANT:** Do not place shims directly under the salt storage tank to level the system. The weight of the tank, when full of water and salt, may cause the tank to fracture at the shim.

2. Visually check and remove any debris from the water treatment system valve inlet and outlet ports. Carefully remove the two large plastic clips (you will use them).
3. Make sure the turbine assembly spins freely in the "out" port of the valve (See Figure 10).
4. If not already done, put a light coating of silicone grease on the single bypass valve o-rings.
5. Push the single bypass valve into the system valve as far as it will go. Snap the two large holding clips into place, from the top down as shown in Figures 11 & 12.

**IMPORTANT:** Be sure the clips snap firmly into place so the single bypass valve will not pull out.



# Installation Instructions

## COMPLETE INLET AND OUTLET PLUMBING

Measure, cut, and loosely assemble pipe and fittings from the main water pipe to the inlet and outlet ports of the water treatment system valve. Be sure to keep fittings fully together, and pipes squared and straight.

Be sure hard water supply pipe goes to the water treatment system valve inlet side.

**NOTE:** Inlet and outlet are marked on the water treatment system valve. Trace the water flow direction to be sure hard water is to inlet.

**IMPORTANT:** Be sure to fit, align and support all plumbing to prevent putting stress on the water treatment system valve inlet and outlet. Undue stress from misaligned or unsupported plumbing may cause damage to the valve.

Complete the inlet and outlet plumbing for the type of pipes you will be using.

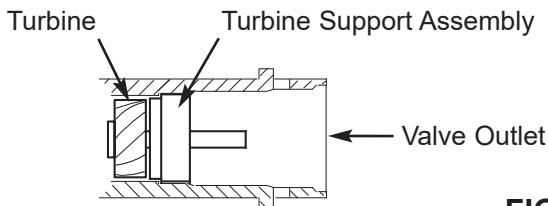

FIG. 10

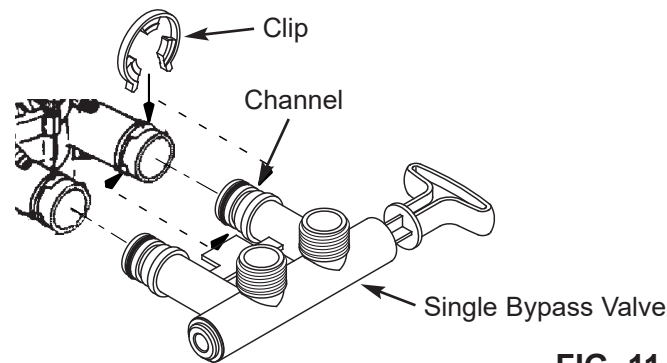

FIG. 11

### Correct Assembly

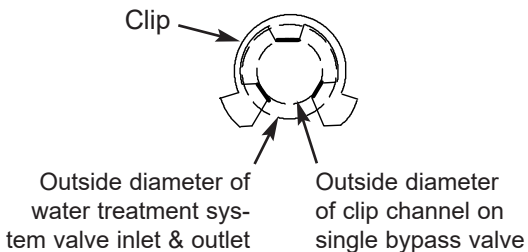

FIG. 12

**NOTE:** Be sure all 3 tabs of the clip go through the matching holes on the water treatment system valve inlet or outlet, and fully into the channel on the single bypass valve. Make sure that the tabs are fully seated.

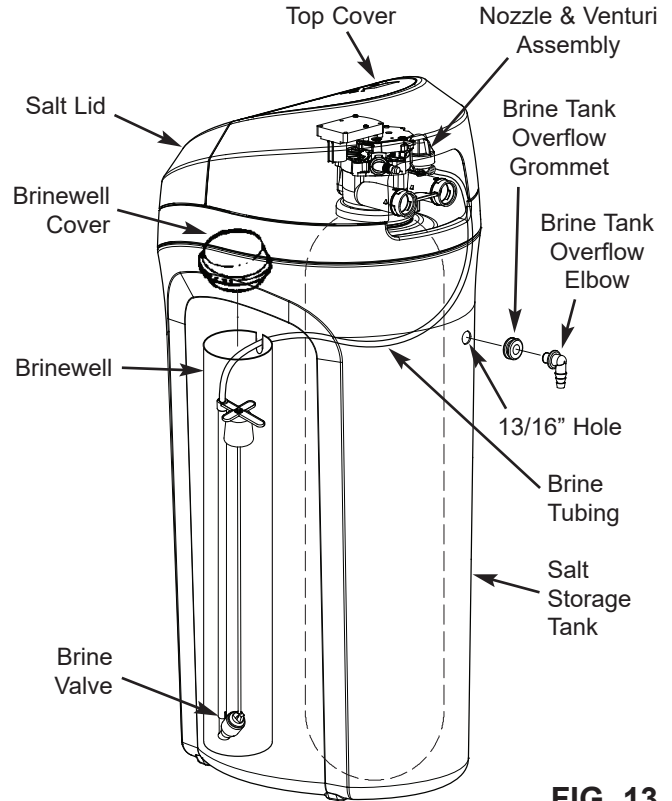

FIG. 13

## COLD WATER PIPE GROUNDING

**CAUTION:** The house cold water pipe (metal only) is often used as a ground for the house electrical system. The 3-valve bypass type of installation, shown in Figure 8, will maintain ground continuity. If you use a plastic bypass valve at the unit, continuity is broken. To restore the ground, do the following:

1. Install a #4 copper wire across the removed section of main water pipe, securely clamping it at both ends (See Figure 14) - parts not included.

**NOTE:** Check local plumbing and electrical codes for proper installation of the ground wire. The installation must conform to them. In Massachusetts, plumbing codes of Massachusetts shall be conformed to. Consult with your licensed plumber.

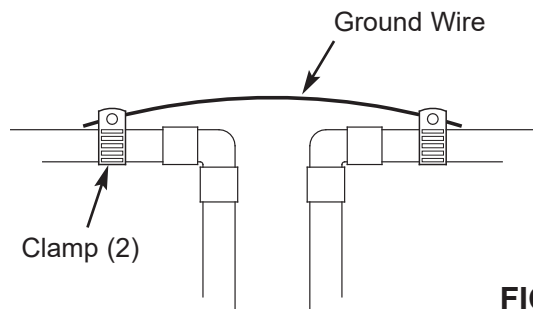

FIG. 14

---

# Installation Instructions

## INSTALL VALVE DRAIN HOSE

**NOTE:** See valve drain options on pages 6 & 7.

1. Measure, cut to needed length and connect the 9.5 mm drain line (provided) to the water treatment system valve drain fitting. Use a hose clamp to hold the hose in place.

**IMPORTANT:** If codes require a rigid drain line see "Valve Drain requirements" section.

2. Run the drain hose (or a rigid line) to the floor drain. Secure drain hose. This will prevent "whipping" during regenerations. **Be sure to provide a 4 cm minimum air gap to prevent possible sewer water backup.** See "Air Gap Requirements" section.

**NOTE:** In addition to a floor drain, you can use a laundry tub or standpipe as a good drain point for this hose.. Avoid long drain hose runs, or elevating the hose more than 2.5 meters above the floor.

## INSTALL SALT STORAGE TANK OVERFLOW HOSE

1. Measure, cut to needed length and connect the 9.5 mm drain line (provided) to the salt storage tank overflow elbow and secure in place with a hose clamp.

2 Route the hose to the floor drain, or other suitable drain point no higher than the drain fitting on the salt storage tank (This is a gravity drain). If the tank overfills with water, the excess water flows to the drain point. Cut the drain line to the desired length and route it neatly out of the way.

**IMPORTANT:** For proper operation of the water treatment system, do not connect the system valve drain tubing to the salt storage tank overflow hose.

## ADD WATER AND SALT TO THE SALT STORAGE TANK

1. Using a container, add about three gallons of clean water into the salt storage tank.
2. Add salt to the storage tank. Use nugget, pellet or coarse solar salts with less than 1% impurities.

## PLUG IN THE POWER SUPPLY

During installation, the water treatment system wiring may be moved or jostled from place. Check to be sure all leadwire connectors are secure on the back of the electronic board and be sure all wiring is away from

the valve gear and motor area, which rotates during regenerations.

1. Plug the water softener's power supply into an electrical outlet that is not controlled by a switch and is approved by local codes.

**NOTE:** The water heater is filled with hard water and, as hot water is used, it will refill with treated water. In a few days, the hot water will be fully treated. To have fully treated hot water immediately, wait until the initial recharge is over. Then, drain the water heater (following instructions for water heater) until water runs cold.

## PROGRAM THE CONTROLLER

1. Install the system's top cover and salt lid.
2. Complete the programming steps on pages 12 & 13.

## RINSE OUT CARBON FINES

Small particles of carbon filtration material are generated during manufacturing and shipping, which will exit the media tank with the first water flow. These carbon "fines" are not harmful, but give the water a gray color and should be rinsed down the drain before any water from the system is directed to the home's faucets or water heater.

**CAUTION:** To avoid water or air pressure damage to system inner parts, and to flush pipe chips or other residue from the water pipes, be sure to do the following steps exactly as instructed.

1. Make sure the water treatment system's valve drain hose is hooked up and the open end directed to a floor drain, laundry tub or other suitable type of drain.
2. The system should be connected to electrical power.
3. Place bypass valve(s) in "bypass" position (see Figures 7 & 8). On a single valve, slide the stem inward to bypass. On a 3-valve bypass, close the inlet and outlet valves and open the bypass valve.
4. Fully open the house main water pipe shutoff valve.
5. Initiate a regeneration by pressing and holding for 3 seconds the RECHARGE button (see Figure 16 on page 12). The valve motor will start running and the valve will advance to the "Fill" position.
6. After you hear the valve motor stop running (valve in "Fill" position), press, but do not hold, the RECHARGE button. The valve will advance to the "Brine" position.

continued on next page

# Installation Instructions

7. After you hear the valve motor stop running (valve in “Brine” position), press, but do not hold, the RECHARGE button. The valve will advance to the “Backwash” position.
8. Once the unit is in backwash, place bypass valve(s) in SERVICE, EXACTLY as follows:
  - a. Single Bypass Valve: Slowly, slide pull the valve stem outward toward service, pausing several times to allow the system to pressurize gradually.
  - b. 3-Valve Bypass: Fully close the bypass valve and open the outlet valve. Slowly open the inlet valve, pausing several times to allow the system to pressurize gradually.
9. Let the water treatment system complete the backwash and fast rinse cycles (takes about 20 minutes). When the regeneration ends, the system’s valve returns to the service position.

## SANITIZE THE WATER SOFTENER / SANITIZE AFTER SERVICE

Care is taken at the factory to keep your unit clean and sanitary. Materials used to make the unit will not infect or contaminate your water supply, and will not cause bacteria to form or grow. However, during shipping, storage, installation and operation, bacteria could get into the unit. For this reason, sanitizing as follows is suggested\* when installing.

1. Slide open the salt lid, remove the brinewell cover and pour about 90 ml (6 tablespoons) of household bleach into the softener brinewell. Replace the brinewell cover.
- 2 Make sure the bypass valve(s) is in the “service” (open) position.
- 3 **Start a recharge:** Press the RECHARGE button and hold for 3 seconds, until “Recharge Now” begins to flash in the display. This recharge draws the sanitizing bleach into and through the water softener. Any air remaining in the unit is purged to the drain.
4. After the recharge has completed, fully open a cold water faucet, downstream from the softener, and allow 190 liters of water to pass through the system. This should take at least 20 minutes. Close the faucet.

\*Recommended by the Water Quality Association. On some water supplies, the unit may need periodic disinfecting.

## TEST FOR LEAKS

To check for leaks, complete the following steps:

1. Fully open two nearby cold water faucets downstream from the water treatment system.
2. Observe steady water flow from both open faucets.
- 3 After about three minutes, open a hot water faucet for about one minute, or until all air is expelled, then close.
4. Close both cold water faucets.
5. Check your plumbing work for leaks, and fix right away if any are found. Be sure to observe previous caution notes.

**NOTE:** If this procedure is performed on a new system, water coming from the taps may initially be discolored. This normally occurs the first time water runs through the resin bed. The discolored water is not harmful, and the discoloration will not last more than a few minutes.

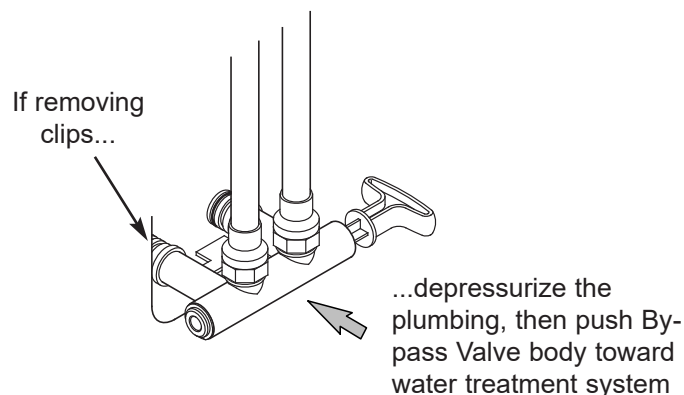

FIG. 15

## RESTART THE WATER HEATER

1. Turn on the electricity or fuel supply to the water heater and relight the pilot, if applicable.

**NOTE:** The water heater is filled with hard water and, as hot water is used, it refills with treated water. In a few days, the hot water will be fully treated. To have fully treated hot water immediately, wait until the initial recharge (previous step) is over. Then, drain the water heater (following instructions for water heater) until water runs cold.

Questions? Call Toll Free 1-800-693-1138 or visit [www.ecopure.com](http://www.ecopure.com)

When you call, please be prepared to provide the model and serial number, found on the rating decal, typically located on the rim below the salt lid hinges.

# Programming the Water Treatment System

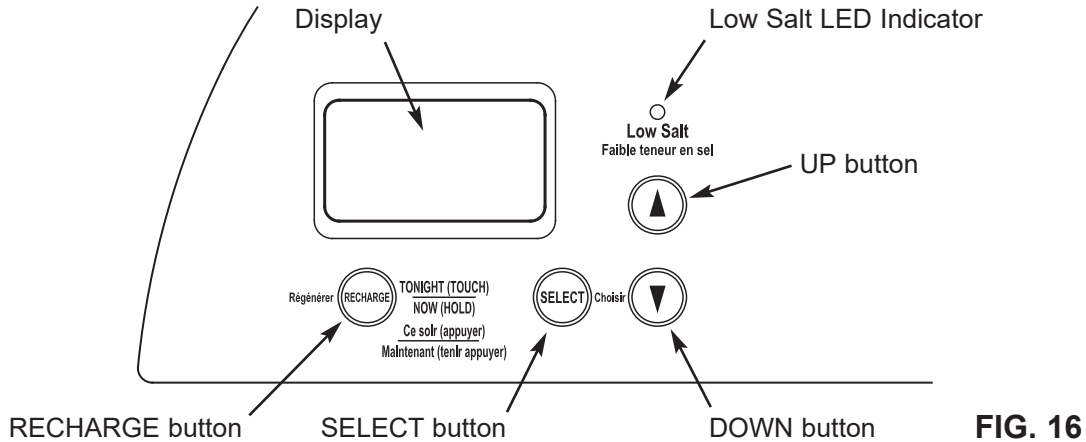

FIG. 16

## LOW SALT LIGHT / CLEAN REMINDER

When the water treatment system is connected to electrical power, the light on the control panel will operate as follows:

- **Light flashing, with the time of day shown in the display** - The salt monitor system indicates a low salt level and needs to be set. See "Set Salt Level" on Page 13.
- **Light flashing, with "CLEAN" flashing in the display** (See Fig. 17) - Four months have elapsed on the system's timer since start up or the last reset.

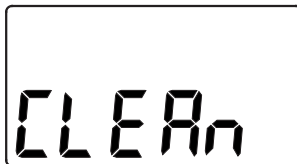

FIG. 17

This is a reminder to use **EcoPure EPCL Water Softener Cleaner** three times a year.

P/N 7346596 • [orders.ecodyne.org](http://orders.ecodyne.org)

To reset the timer, press any button on the control panel and "CLEAN" will disappear. The light will stop flashing, unless the system is also low on salt (see above).

## PROGRAM THE SYSTEM

When the power supply is plugged into the electrical outlet, the model code and a software version number (example: J3.9), are briefly shown in the display. Then the words "PRESENT TIME" appear and "12:00 PM" begins to flash.

**NOTE:** If "- - -" shows in the display, press the ▲ UP or ▼ DOWN button until the model code ("EPHY" for Model EPHY) shows in the display. Then, press the SELECT button to set, and change to the flashing "SET TIME" display.

## SET TIME OF DAY

If the words "SET TIME" do not show in the display, press the SELECT button until they do.

1. Press the ▲ UP or ▼ DOWN buttons to set the present time. Up moves the display ahead; down sets the time back. Be sure AM or PM is correct.

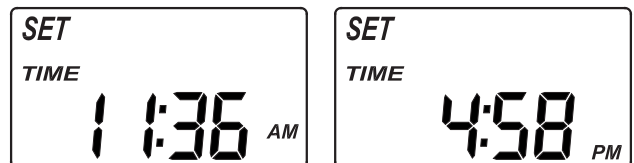

FIG. 18

**NOTE:** Press buttons and quickly release to slowly advance the display. Hold the buttons down for fast advance.

continued on next page

**Questions? Call Toll Free 1-800-693-1138** or visit [www.ecopure.com](http://www.ecopure.com)

When you call, please be prepared to provide the model and serial number, found on the rating decal, typically located on the rim below the salt lid hinges.

# Programming the Water Treatment System

## SET WATER HARDNESS NUMBER

1. Press the SELECT button once again to display a flashing "25" and the word "HARDNESS".



FIG. 19

2. Press the ▲ UP or ▼ DOWN buttons to set your water's hardness number.

**NOTE:** If your water supply contains iron, compensate for it by adding to the water hardness number. For example, assume your water is 20 gpg hard and contains 2 ppm iron. Add 5 to the hardness number for each 1 ppm of iron. In this example, you would use 30 for your hardness number.

$$\begin{array}{r} 20 \text{ gpg hardness} \\ 2 \text{ ppm iron} \times 5 = 10 \\ \text{(times)} \quad \underline{\quad +10} \\ \hline 30 \text{ HARDNESS NUMBER} \end{array}$$

**NOTE:** If you use potassium chloride (KCl) salt instead of sodium chloride (NaCl) salt in this softener, increase the hardness setting by 25%. For example, if you will be using KCl and your water supply's hardness is 20 gpg, set the softener to 25 gpg.

## SET RECHARGE (REGENERATION) TIME

Your demand water treatment system will automatically regenerate when it needs to, based on water usage. The time of day that the automatic recharge cycle begins may be changed as follows:

1. Press the SELECT button once again to display a flashing "2:00AM" and the words "SET RECHARGE TIME". This is a good time for the recharge to start in most households, because water is not in use.

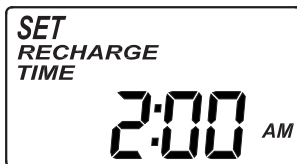

FIG. 20

2. If you want to change the recharge start time, press the ▲ UP or ▼ DOWN buttons until the desired time shows. Be sure AM or PM is correct.

## SET SALT LEVEL

The water treatment system has a low salt indicator light to remind you to refill the storage tank with salt.

**NOTE:** You must set salt level each time salt is added to the water softener.

To set this monitor system:

1. Lift the salt lid and level the salt in the storage tank.
2. The salt level scale, on the brinewell inside the tank, has numbers from 0 to 8 (See Fig. 21). Observe the highest number the leveled salt is at, or closest to.

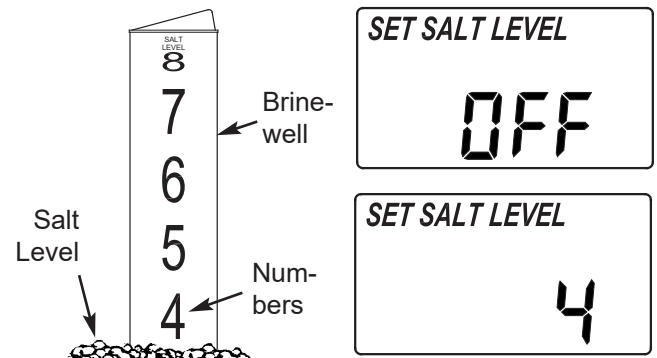

FIG. 21

3. Press the SELECT button to display the words "SET SALT LEVEL".
4. Press the ▲ UP or ▼ DOWN buttons until the number on the screen corresponds to the salt level. At level 2 or below, the "Low Salt" indicator light will flash. If you wish to turn this feature off, press the ▼ DOWN button past 0, and the word "OFF" flashes in the display.
5. Press the SELECT button once more to complete the initial programming. The current time of day will show in the display.

---

# Programming the Water Treatment System

## RECHARGE NOW

At times of greater than normal water use, such as when you have guests, you could run out of treated water before the next scheduled recharge. If this happens, you may want to initiate an immediate regeneration, as follows:

1. Press **and hold** the RECHARGE button until the words "RECHARGE NOW" flash in the display.

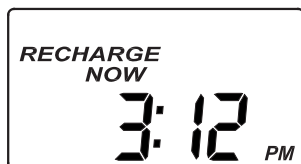

FIG. 22

RECHARGE NOW initiated

The system enters the fill cycle of regeneration right away. "RECHARGE NOW" will flash during the regeneration. When completed (in about 2 hours), full water treatment capacity is restored.

**NOTE:** Avoid using hot water while the system is regenerating, because the water heater will refill with bypass hard water.

## RECHARGE TONIGHT

If you do not want to start an immediate recharge, but would like an extra recharge at the next preset recharge time, do the following to schedule a recharge:

1. Press and release (do not hold) the RECHARGE button.



FIG. 23

RECHARGE TONIGHT initiated

The words "RECHARGE TONIGHT" flash in the display, and the water treatment system will recharge at the next preset recharge time (If you decide to cancel the regeneration before it begins, press and release the RECHARGE button once more, and "RECHARGE TONIGHT" will disappear from the display). During regeneration, the word "RECHARGE NOW" will flash in the screen. When completed, full water treatment capacity is restored.

# Customizing Features / Options

## SET SALT EFFICIENCY

When this feature is ON, the water softener will operate at salt efficiencies of 4000 grains of hardness per pound of salt or higher (May recharge more often using smaller salt dosage but more regeneration water). The softener is shipped with this feature set OFF.

1. Press and hold the SELECT button until one of the screens in Figure 24 is displayed. Once in this display, press the SELECT button once again and one of the two displays in Figure 25 is shown.

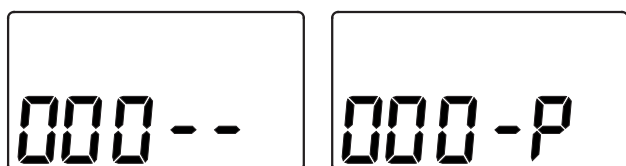

FIG. 24

2. Press the ▲ UP or ▼ DOWN buttons to set ON or OFF. When set to ON, the efficiency icon will be displayed on the right hand side of the normal run display.

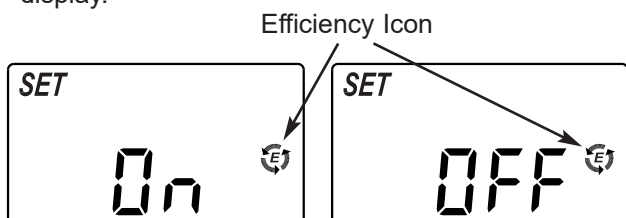

FIG. 25

3. Press the SELECT button six times, to return to the normal run display (See Figure 26).

Displayed when efficiency is set to "ON"

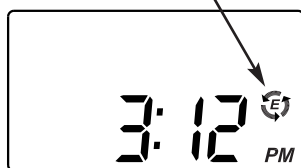

FIG. 26

## CLEAN FEATURE

This feature is beneficial on water supplies containing iron and/or high amounts of sediments (sand, silt, dirt, etc.). When set to ON, a backwash and fast rinse cycle will occur first, preceding the normal regeneration sequence. This provides extra cleaning of the resin bed before it is regenerated with the salt brine. To conserve water, if your water supply does not contain iron or sediments, be sure this feature is set to OFF. The default is OFF.

To change between OFF and ON:

1. Press and hold the SELECT button until the screen in Figure 27 is displayed.

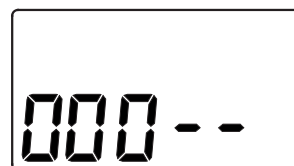

FIG. 27

2. Press the SELECT button twice again, so that "SET CLEAN OFF" or "SET CLEAN ON" flashes in the display (See Figure 28).

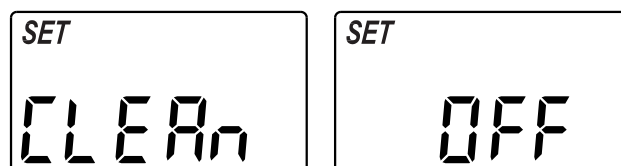

FIG. 28

3. Use the ▲ UP or ▼ DOWN buttons to change between OFF and ON.
4. When the desired Clean Feature setting appears in the display, press the SELECT button five times to return to the normal run (time of day) screen.

## CLEAN FEATURE MINUTES

If you have set the Clean Feature ON, the length of the extra backwash cycle automatically is set to 6 minutes. However, you can adjust this time from 1 to 15 minutes in length.

To change this cycle time:

1. Press and hold the SELECT button until the screen in Figure 29 is displayed.
2. Press the SELECT button three times to display the "Set Clean Time" screen (See Figure 29).

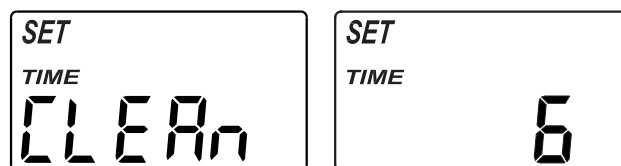

FIG. 29

# Customizing Features / Options

3. Use the ▲ UP or ▼ DOWN buttons to set the length of the clean time in minutes.
4. When the desired clean time appears in the display, press the SELECT button four times to return to the normal run (time of day) screen.

## 12 OR 24 HOUR CLOCK

All time displays are shown in standard clock time (1 to 12 AM; and 1 to 12 PM) at the “12 hr” default setting.

To change this setting:

1. Press and hold the SELECT button until the screen in Figure 24 is displayed.
2. Press the SELECT button four times, so that “12 hr” or “24 hr” flashes in the display (See Figure 30).

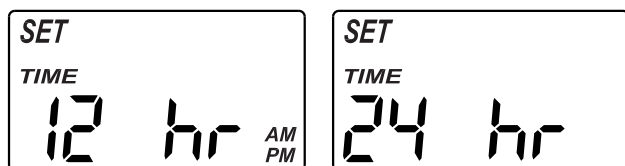

FIG. 30

3. Use the ▲ UP or ▼ DOWN buttons to change between “12 hr” and “24 hr”.
4. When the desired setting appears in the display, press the SELECT button three times to return to the normal run (time of day) screen.

## ADJUSTABLE BACKWASH

If your incoming water supply has higher sediments or clear water iron, a longer Backwash and/or Fast Rinse time may help in keeping the unit cleaner.

To change the length of the Backwash:

1. Press and hold the SELECT button until the screen in Figure 24 is displayed.
2. Press the SELECT button five times, so that “SET TIME bA” appears in the display (See Figure 31).

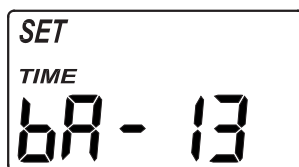

FIG. 31

3. Press the ▲ UP or ▼ DOWN buttons to set the length of Backwash in minutes.\*
4. When the desired Backwash time appears in the display, press the SELECT button twice to return to the normal run (time of day) screen.

\* Setting backwash and/or fast rinse times too low may result in salty tasting water after regeneration.

## ADJUSTABLE FAST RINSE

To change the length of the Fast Rinse:

1. Press and hold the SELECT button until the screen in Figure 27 is displayed.
2. Press the SELECT button six times, so that “SET TIME Fr” appears in the display (See Figure 32).



FIG. 32

3. Press the ▲ UP or ▼ DOWN buttons to set the length of Fast Rinse in minutes.\*
4. When the desired Fast Rinse time appears in the display, press the SELECT button once to return to the normal run (time of day) screen.

## CLEANSING FEATURE

The cleansing feature keeps larger particles of sediment from entering the home’s plumbing system. As water passes through the softener, the larger sediment particles are collected in the integrated basket and then rinsed to the drain before each regeneration. The cleansing feature provides added protection for water using appliances by reducing the chance of larger particles entering the various products valves and screens. The “Clean Feature” may be turned ON to provide an extra backwash that will help keep the cleansing screen clean. The default is OFF.

**IMPORTANT:** The cleansing feature is not intended to replace pretreatment filtration. For problem water applications, additional sediment filtration is recommended.

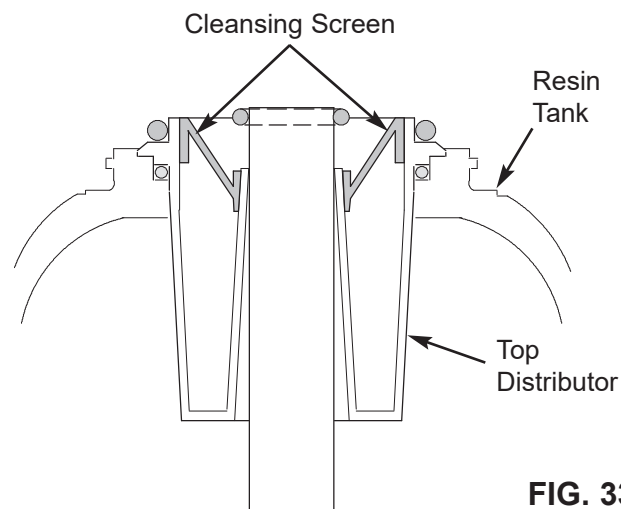

FIG. 33



## Features / Options

### POWER OUTAGE MEMORY

If electrical power to the water treatment system is lost, "memory" built into the timer circuitry will keep all settings for several hours. While the power is out, the display is blank and the system will not regenerate. When electrical power is restored, the following will occur.

You have to reset the present time only if the display is flashing. The HARDNESS and RECHARGE TIME never require resetting unless a change is desired. Even if the clock is incorrect after a long power outage, the system operates as it should to keep your water soft. However, regenerations may occur at the wrong time of day until you reset the clock to the correct time of day.

**NOTE:** If the water treatment system was regenerating when power was lost, it will now finish the cycle.

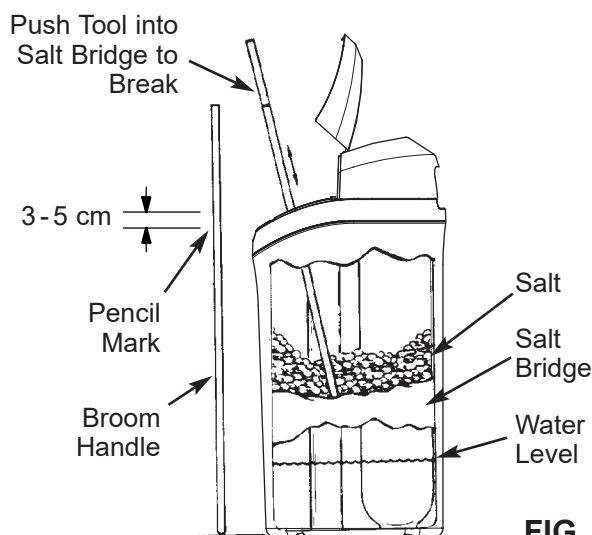

FIG. 34

## Routine Maintenance

### ADDING SALT

Lift the salt lid and check the salt storage level frequently. If the water treatment system uses all the salt before you refill it, you will experience hard water. Until you have established a refilling routine, check the salt every two or three weeks. Always add if less than 1/4 full. Be sure the brinewell cover is on.

**NOTE:** In humid areas, it is best to keep the salt storage level lower, and to refill more often to avoid salt "bridging".

**Recommended Salt:** Nugget, pellet or coarse solar salts with less than 1% impurities.

**Salt Not Recommended:** Rock salt, high in impurities, block, granulated, table, ice melting, ice cream making salts, etc.

### BREAKING A SALT BRIDGE

Sometimes, a hard crust or salt "bridge" forms in the brine tank. It is usually caused by high humidity or the wrong kind of salt. When the salt "bridges," an empty space forms between the water and the salt. Then, salt will not dissolve in the water to make brine. Without brine, the resin bed is not recharged and hard water will result.

If the storage tank is full of salt, it is difficult to tell if you have a salt bridge. A bridge may be underneath loose salt. Take a broom handle, or like tool, and hold it next to the water treatment system. Measure the distance from the floor to the rim of the water treatment system. Then, gently push the broom handle straight down into the salt. If a hard object is felt before the pencil mark is even with the top, it is most likely a salt bridge. Gently push into the bridge in several places to break it. Do not use any sharp or pointed objects as you may puncture the brine tank. Do not try to break the salt bridge by pounding on the outside of the salt tank. You may damage the tank.

# Routine Maintenance

## CLEANING THE NOZZLE & VENTURI

A clean nozzle & venturi (See Figure 35) is a necessity for the water treatment system to work properly. This small component creates the suction to move brine from the brine tank, into the resin tank. If it should become plugged with sand, silt, dirt, etc., the system will not work, and hard water will result.

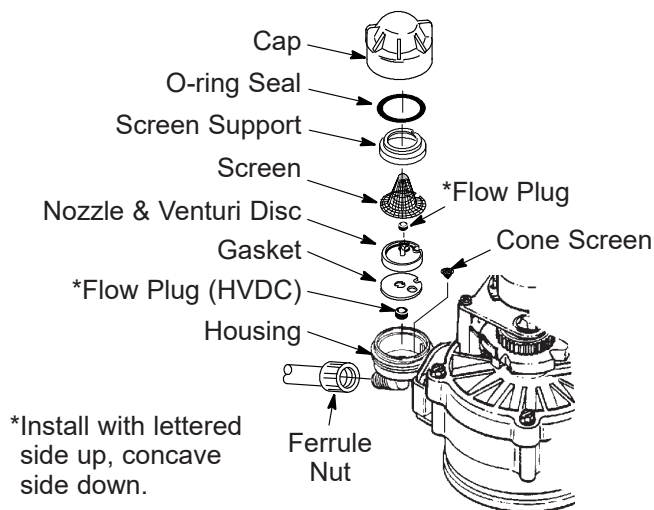

**IMPORTANT:** Be sure small hole in the gasket is centered directly over the small hole in the nozzle & venturi housing. Be sure the numbers are facing up.

**FIG. 35**

To get access to the nozzle & venturi, remove the water treatment system's top cover. Put the bypass valve(s) into the bypass position. Be sure the system is in soft water (service) cycle (no water pressure at nozzle & venturi). Then, holding the nozzle & venturi housing with one hand, unscrew the cap. Do not lose the o-ring seal. Lift out the screen support and screen. Then, remove the nozzle & venturi disc, gasket and flow plug(s). Wash the parts in warm, soapy water and rinse in fresh water. Be sure to clean both the top and bottom of the nozzle & venturi disc. If needed, use a small brush to remove iron or dirt. Do not scratch, misshape, etc., surfaces of the nozzle & venturi.

Gently replace all parts in the correct order. Lubricate the o-ring seal with silicone grease and locate in place. Install and tighten the cap by hand, while supporting the housing. Overtightening may break the cap or housing. Put the bypass valve(s) into service (soft water) position.

Recharge the water treatment system to reduce water level in the tank. This will also assure that the system is completely recharged and ready to provide softened water again. Check the water level in the tank by looking down the brinewell. If the water level does not drop after a recharge, the problem has not been resolved. Call 1-800-693-1138.

## PROTECT THE WATER TREATMENT SYSTEM FROM FREEZING

If the water treatment system is installed where it could freeze (summer cottage, lake home, etc.), you must drain all water from it to stop possible freeze damage. To drain the system:

1. Close the shut-off valve on the house main water pipe, near the water meter or pressure tank.
2. Open a faucet in the treated water pipes to vent pressure in the system.
3. Move the stem in the single bypass valve to bypass. Close the inlet and outlet valve in a 3 valve bypass system, and open the bypass valve. If you want water in the house pipes again, reopen the shut-off valve on the main water pipe.
4. Unplug the power supply at the wall outlet. Slide open the salt lid and remove the water treatment system's top cover. Take off both drain hoses if they will interfere with moving the system into position over the drain.
5. Carefully remove the large holding clips at the water treatment system inlet and outlet. Separate the system from the plastic installation adaptors, or from the bypass valve.
6. Lay a piece of 5 cm thick board near the floor drain (See Figure 36).
7. Move the water treatment system close to the drain. Slowly and gently, tip it over until the rim rests on the wood block with the inlet and outlet over the drain. Do not allow the system's weight to rest on the inlet and outlet fittings or they may break.
8. Tip the bottom of the water treatment system up a few centimeters and hold until all water has drained. Leave the system laying like this until you are ready to use it. Plug the inlet and outlet with clean rags to keep dirt, bugs, etc. out.

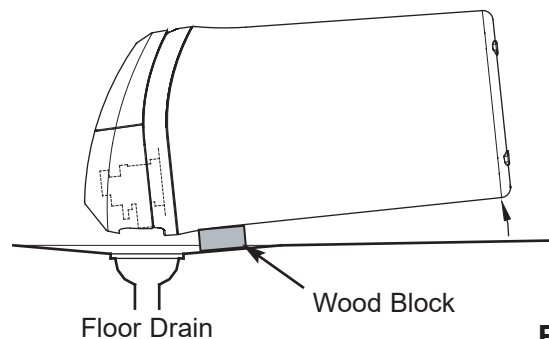

**FIG. 36**

# Troubleshooting Guide

PROBLEM	CAUSE	CORRECTION
<b>No soft water</b>	1. No salt in the storage tank.	Refill with salt and then use RECHARGE NOW feature.
<b>No soft water &amp; display is blank</b>	1. Power supply unplugged at wall outlet, or power cable disconnected from back of electronic board or power supply malfunction.	Check for loss of power and correct. Reset electronic controls and then use RECHARGE NOW feature.
	2. Fuse blown, circuit breaker popped, or circuit switched off (See "Power Outage Memory" on Page 17).	Replace fuse, reset circuit breaker, or switch circuit on, and then use RECHARGE NOW feature.
	3. Electronic control board malfunction.	Replace electronic control board (See Page 23).
<b>No soft water &amp; salt level not dropping</b>	1. Salt storage tank "bridged".	Refer to "Breaking a Salt Bridge" section to break.
	2. Bypass valve(s) in "bypass" position.	Move bypass valve(s) to "service" position.
<b>No soft water &amp; salt storage tank full of water, water running to drain while unit is in the soft water cycle</b>	1. Dirty, plugged or damaged nozzle & venturi assembly	Take apart, clean and inspect nozzle & venturi (See "Cleaning the Nozzle & Venturi" section).
	2. Inner valve fault causing leak.	Replace seals and rotor.
	3. Valve drain hose is plugged.	Hose must not have any kinks, sharp bends or any water flow blockage (See "Valve Drain Requirements" section).
	4. Valve drain line and Salt Storage Tank overflow drain connected together by a tee.	Disconnect tee and run separate drain lines.
	5. Low or high system water pressure (low pressure may disrupt brine draw during recharge, high pressure may cause inner valve parts failure).	If pressure is low, increase well pump output to a minimum 20 psi. If daytime pressure is over 100 psi, add a pressure reducing valve in the supply pipe to the water treatment system. Contact a licensed plumber.
	6. Brine float dirty or broken.	Clean or replace Brine Valve Float Assembly.
	7. Leak between valve and resin tank.	Replace o-rings between resin tank and valve.
<b>Water hard sometimes</b>	1. Incorrect time set.	Check and change time setting.
	2. Incorrect water hardness set.	Refer to "Set Water Hardness" section to set correctly.
	3. Incorrect model code programmed.	Refer to "Program the Water Treatment System" section to set correctly.
	4. Hot water being used when system is regenerating.	Avoid using hot water while the system is regenerating, as the water heater will fill with hard water.
	5. Possible increase in water hardness.	Test untreated water for hardness and iron, and program the water treatment system accordingly (See "Set Water Hardness") section to set.
	6. Leaking faucet or toilet valve. Excessive water usage.	A small leak can waste hundreds of gallons of water in a few days. Fix all leaks and always fully close faucets.
<b>Iron in water</b>	1. Clear water iron in water supply.	Test untreated water for hardness and iron, and program the water treatment system accordingly (See "Set Water Hardness") section to set.
	2. Iron in soft water.	Clean resin bed with Resin Bed Cleaner. Follow instructions on package.
	3. Bacterial or organic bound iron.	Cannot be treated by this system.
<b>Resin in household plumbing</b>	1. Crack in distributor or riser tube.	Replace resin tank assembly.
<b>Salt storage tank leaking</b>	1. Crack in brine tank.	Replace salt storage tank assembly.
<b>Motor stalled or clicking</b>	1. Motor malfunction or internal valve fault causing high torque on motor.	a. Replace rotor/seal. b. Replace motor & switch.
<b>Error code E1, E3 or E4 appears</b>	1. Fault in wiring harness or connections to position switch.	Replace wiring harness or connections to position switch.
	2. Fault in switch.	Replace switch.
	3. Fault in valve causing high torque.	Replace rotor/seal.
	4. Motor inoperative.	Replace motor.
<b>Error code E5</b>	1. Electronic control malfunction.	Replace electronic control board.

# Troubleshooting

## AUTOMATIC ELECTRONIC DIAGNOSTICS

This water treatment system has a self-diagnostic function for the electrical system (except input power and/or water meter). The system monitors electronic components and circuits for correct operation. If a malfunction occurs, an error code appears in the display.

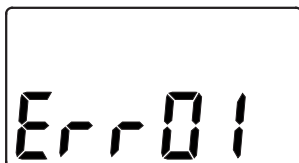

FIG. 37

While an error code appears in the display, all buttons are inoperable except the SELECT button. SELECT remains operational so the service person can perform the Manual Advance Diagnostics, see below, to further isolate the problem.

### Procedure for removing error code from display:

1. Unplug power supply from electrical outlet.
2. Correct problem.
3. Plug power supply back in.
4. Wait 8 minutes. The error code will return if the problem was not corrected.

## MANUAL ADVANCE DIAGNOSTICS

Use the following procedures to advance the water treatment system through the regeneration cycles to check operation.

Remove the top cover to expose the valve and observe cam and switch operation during valve rotation.

1. Press and hold SELECT for 3 seconds until "000" shows in the display, then release.
2. The 3 digits indicate water meter operation as follows:
  - 000 (steady) = Soft water not in use, and no flow through the meter.
  - Open a nearby soft water faucet.
  - 000 to 199 (continual) = Repeats for each gallon of water passing through the meter.
3. The letter "P" and a dash (or dashes) indicate POSITION switch operation (See Figure 38). If the

letter appears, the switch is closed. If the dash shows, the switch is open.

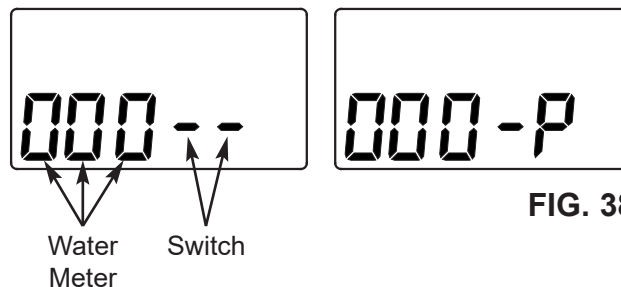

FIG. 38

4. Use the RECHARGE button to manually advance the valve into each cycle and check correct switch operation.

**NOTE:** Be sure water is in contact with the salt, and not separated by a salt bridge (See "Breaking A Salt Bridge" section).

5. While in this diagnostic screen, the following information is available and may be beneficial for various reasons. This information is retained by the computer from the first time electrical power is applied to the electronic controller.
  - a. Press the ▲ UP button to display the number of days this electronic control has had electrical power applied.
  - b. Press the ▼ DOWN button to display the number of regenerations initiated by this electronic control since the code number was entered.
6. Press and hold the SELECT button until the model code ("EPHY" for Model EPHY) shows in the display. This code identifies the water treatment system model. If an incorrect model code is displayed, the system will operate on incorrect configuration data.



FIG. 39

7. To change the code number, press the ▲ UP or ▼ DOWN button until the correct code shows.
8. To return to the present time display, press the SELECT button.

# Troubleshooting

## RESETTING TO FACTORY DEFAULTS

To reset the electronic controller to its factory default for all settings (time, hardness, etc.):

1. Press the SELECT button and hold it until the display changes twice to show "SET CODE" and the flashing model code.
2. Press the ▲ UP button (a few times, if necessary) to display a flashing "SoS".

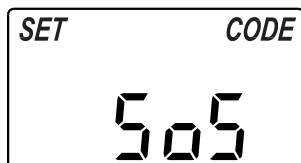

FIG. 40

3. Press the SELECT button, and the electronic controller will restart.
4. Set the present time, hardness, etc., as described on pages 12 & 13.

## MANUAL ADVANCE REGENERATION CHECK

This check verifies proper operation of the valve motor, brine tank fill, brine draw, regeneration flow rates, and other controller functions. Always make the initial checks, and the manual initiated diagnostics.

**NOTE:** The electronic control display must show a steady time (not flashing). If an error code shows, first press the SELECT button to enter the diagnostic display.

1. Press the RECHARGE button and hold in for 3 seconds. RECHARGE begins to flash as the system's valve advances from the service to fill position. Remove the brinewell cover and, using a flashlight, observe fill water entering the tank.

If water does not enter the tank, look for an obstructed nozzle, venturi, fill flow plug, brine tubing, or brine valve riser pipe.

2. After observing fill, press the RECHARGE button to move the system's valve into the brine position. A slow flow of water to the drain will begin. Verify brine draw from the brine tank by shining a flashlight into the brinewell and observing a noticeable drop in the liquid level. This may take 15 to 20 minutes.

**NOTE:** Be sure water is in contact with the salt, and not separated by a salt bridge (See "Breaking A Salt Bridge" section).

If the water treatment system does not draw brine, check for (most likely to least likely):

- Dirty or plugged nozzle and venturi, see "Cleaning the Nozzle and Venturi" section.
- Nozzle and venturi not seated on the gasket, or gasket deformed.
- Valve seals leaking.
- Restriction in valve drain, causing a back-pressure (bends, kinks, elevated too high, etc.). See "Install Valve Drain Hose" section.
- Obstruction in brine valve or brine tubing.

**NOTE:** If water system pressure is low, an elevated drain hose may cause back pressure, stopping brine draw.

3. Press the RECHARGE button to move the system's valve into the backwash position. Look for a fast flow of water from the drain hose. Check that the drain can adequately handle the flow and volume.  
An obstructed flow indicates a plugged top distributor, backwash flow plug, or drain hose.
4. Press the RECHARGE button to move the system's valve into the fast rinse position. Again look for a fast drain flow. Allow the water treatment system to rinse for a few minutes to flush out any brine that may remain in the resin tank from the brining cycle test.
5. To return the system's valve to the service position, press the RECHARGE button.

**Need help troubleshooting? Call Toll Free 1-800-693-1138 or visit [www.ecopure.com](http://www.ecopure.com)**

When you call, please be prepared to provide the model and serial number, found on the rating decal, located on the rim below the salt lid hinges.

# Water Treatment System Exploded View

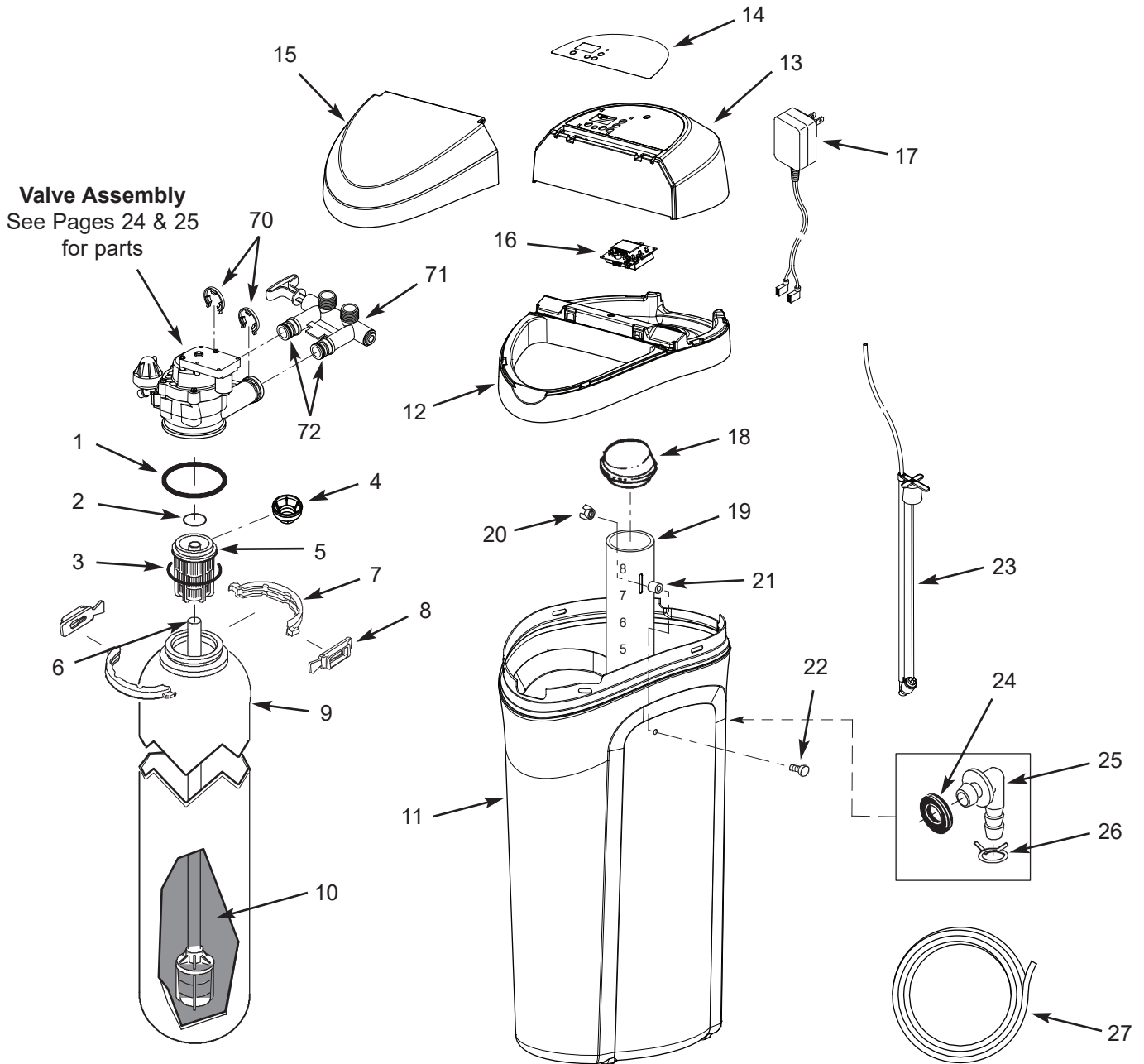

# Water Treatment System Parts List

Key No.	Part No.	Description
–	7112963	Distributor O-Ring Kit (includes Key Nos. 1-3)
1	↑	O-Ring, 73.0 x 82.6 mm
2	↑	O-Ring, 20.6 x 27.0 mm
3	↑	O-Ring, 69.9 x 76.2 mm
4	7265025	Filter Screen
5	7077870	Top Distributor
6	7105047	Repl. Bottom Distributor
–	7331177	Tank Neck Clamp Kit (includes Key Nos. 7 & 8)
7	↑	Clamp Section (2 req.)
8	↑	Retainer Clip (2 req.)
9	7334696	Repl. Resin Tank, 25.4 x 88.9 cm
10	0502272	Resin, 1 cu. ft.
	7301619	Activated Carbon
11	7383742	Brine Tank ★
12	7388302	Rim ★
13	7330985	Top Cover (order decal below)
14	7344552	Faceplate Decal
15	7330993	Salt Lid (order decal below)
■	7334230	Instruction Decal

Key No.	Part No.	Description
16	7331834	Repl. Electronic Control Board (PWA)
17	7351054	Power Supply, 24V DC
18	7155115	Cover, Brinewell
19	7214375	Brinewell
–	7332204	Brinewell Mounting Hardware Kit (includes Key Nos. 20-22)
20	↑	Wing Nut, 1/4-20
21	↑	Spacer, 19.1 mm long
22	↑	Screw, 1/4-20 x 15.9 mm
23	7380948	Brine Valve Assembly
–	7331258	Overflow Hose Adaptor Kit (includes Key Nos. 24-26)
24	↑	Grommet
25	↑	Adaptor Elbow
26	↑	Hose Clamp
27	7139999	Drain Hose
■	7388352	Owner's Manual

★ If replacing either a brine tank or a rim, you must replace them both if the date code of your model is below 20309. The 5-digit date code is the middle part of the serial number on the rating decal (Example: EPHY014-**20309**-1001).

■ Not illustrated.

To order repair parts call toll free 1-800-693-1138.

Manufactured and warranted by  
Water Channel Partners  
1890 Woodlane Drive  
Woodbury, MN 55125

**Questions? Call Toll Free 1-800-693-1138** or visit **www.ecopure.com**

When you call, please be prepared to provide the model and serial number, found on the rating decal, typically located on the rim below the salt lid hinges.

# Valve Exploded View

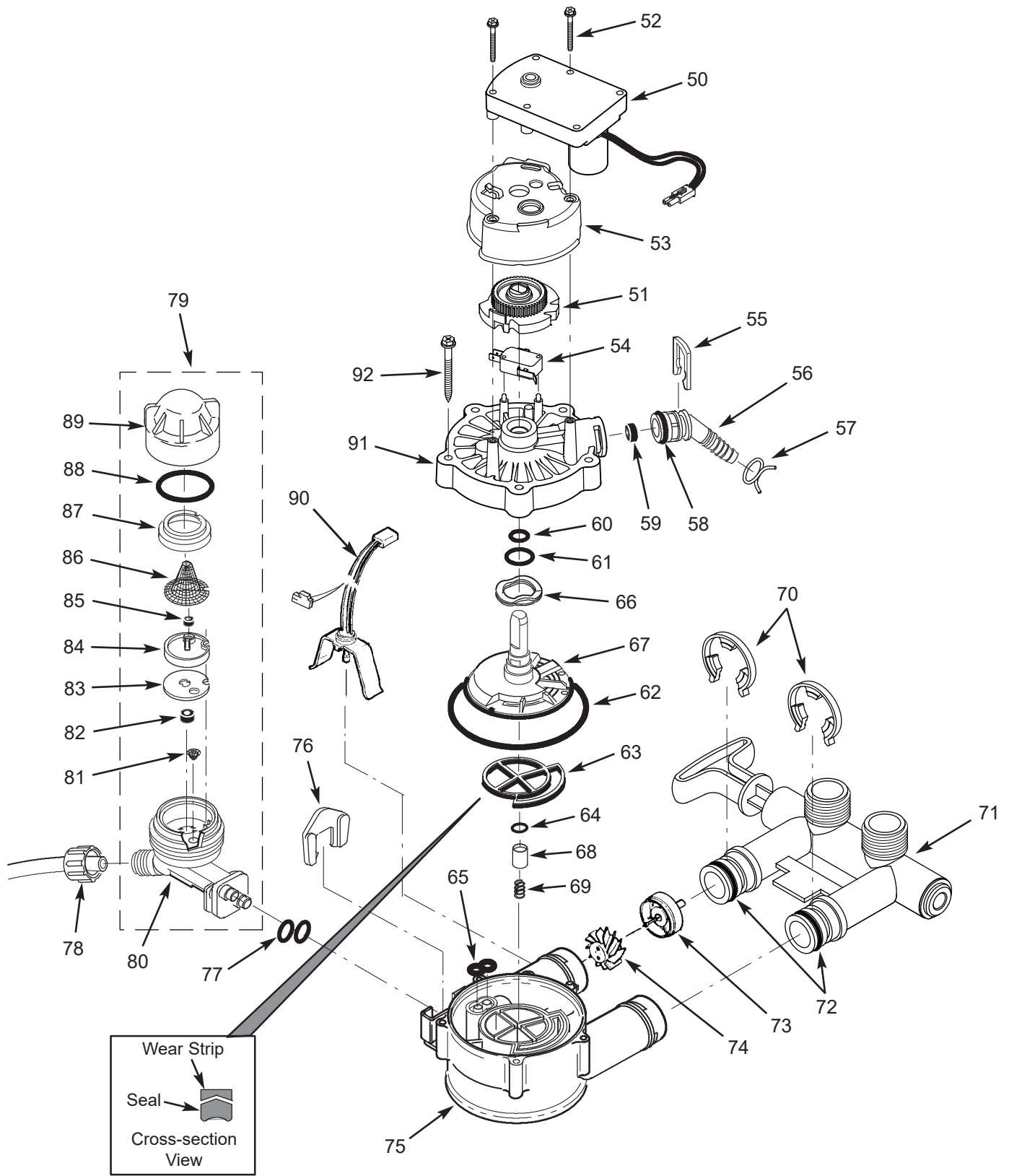



# Valve Parts List

Key No.	Part No.	Description
–	7384683	Motor, Cam & Gear Kit, 3/4" (includes Key Nos. 50-52)
50	↑	Motor
51	↑	Cam & Gear
52	7338111	Screw, #6-19 x 3.5 cm (2 req.)
53	7337474	Motor Mount
54	7030713	Switch
–	7331185	Drain Hose Adaptor Kit (includes Key Nos. 55-59)
55	↑	Clip, Drain
56	↑	Drain Hose Adaptor
57	↑	Hose Clamp
58	↑	O-Ring, 15.9 x 20.6 mm
59	↑	Flow Plug, 7.6 lpm
–	7129716	Seal Kit (includes Key Nos. 60-65)
60	↑	O-Ring, 11.1 x 15.9 mm
61	↑	O-Ring, 19.1 x 23.8 mm
62	↑	O-Ring, 85.7 x 92.1 mm
63	↑	Rotor Seal
64	↑	O-Ring, 9.5 x 14.3 mm
65	↑	Seal, Nozzle & Venturi
66	7082087	Wave Washer
67	7199232	Rotor & Disc
–	7342665	Drain Plug Kit, 3/4" (includes Key Nos. 64, 68 & 69)
68	↑	Plug, Drain Seal
69	↑	Spring
70	7337563	Clip, 3/4", pack of 4

Key No.	Part No.	Description
71	7370286	Bypass Valve Assembly, 3/4", including 2 O-Rings (See Key No. 72)
72	7337571	O-Ring, 23.8 x 30.2 mm, pack of 4
–	7113040	Turbine & Support Assembly, including 2 O-Rings (See Key No. 72) & 1 ea. of Key Nos. 73 & 74
73	↑	Turbine Support & Shaft
74	↑	Turbine
75	7082053	Valve Body
76	7081201	Retainer, Nozzle & Venturi
77	7342649	O-Ring, 6.4 x 9.5 mm, pack of 2
78	1202600	Nut - Ferrule
79	7257454	Nozzle & Venturi Assembly, (includes Key Nos. 76, 77 & 80-89)
80	↑	Housing, Nozzle & Venturi
81	↑	Cone Screen
82	↑	Flow Plug, 1.1 lpm
83	↑	Gasket
84	↑	Nozzle & Venturi Disc, Blue
85	↑	Flow Plug, 0.57 lpm
86	↑	Screen
87	↑	Screen Support
88	↑	O-Ring, 28.6 x 34.9 mm
89	↑	Cap
■	7298913	Repl. Nozzle, Venturi & Gasket Kit, (incl. Key Nos. 77, 81, 83, 84 & 88)
90	7309803	Wire Harness, Sensor
91	7337466	Valve Cover
92	7342657	Screw, #10-14 x 5 cm, pack of 5

■ Not illustrated

To order repair parts call toll free 1-800-693-1138.

Manufactured and warranted by  
Water Channel Partners  
1890 Woodlane Drive  
Woodbury, MN 55125

**Questions? Call Toll Free 1-800-693-1138** or visit **www.ecopure.com**

When you call, please be prepared to provide the model and serial number, found on the rating decal, typically located on the rim below the salt lid hinges.

---

## **EXTEND YOUR WARRANTY: Use EcoPure EPCL Water Softener Cleaner**

The factory warranty for your whole home water treatment system is shown below. The one year full warranty period on parts and labor can be extended to five (5) years from the date the product is delivered if you use EcoPure EPCL Water Softener Cleaner on your system. Use one bottle of EcoPure EPCL Water Softener Cleaner, as directed, every four months from the date the whole home water treatment system is delivered. Retain proof of purchase of EcoPure EPCL Water Softener Cleaner to validate any warranty claim after the first year. Purchase of no more than three (3) bottles of EcoPure EPCL Water Softener Cleaner in a 12 month period may be applied toward compliance with this warranty. Use of any water softener additive other than EcoPure EPCL will not provide extended warranty coverage.

### **WHOLE HOME WATER TREATMENT SYSTEM WARRANTY - MODEL EPHY**

**Warrantor: Water Channel Partners, 1890 Woodlane Drive, Woodbury, MN 55125**

Warrantor guarantees to the original purchaser when the product is purchased from an authorized dealer, and when installed and maintained in accordance with the instructions, that:

#### **One Year Full Warranty:**

- For a period of one (1) year from the date the product is delivered, all parts will be free from defects in materials and workmanship and will perform in accordance with their written specifications.
- For a period of one (1) year from the date the product is delivered, labor to repair or replace any part determined by Warrantor to be defective in materials or workmanship, will be provided at no additional cost.

#### **Limited Warranties:**

- For a period of ten (10) years from the date the product is delivered, the salt storage tank and fiberglass resin/mineral tank will not rust, corrode, leak, burst, or in any other manner, fail to perform in accordance with their written specifications.
- For a period of three (3) years from the date the product is delivered, the electronic control board will be free of defects in materials and workmanship and will perform in accordance with its written specifications.

If, during such respective period, a part proves to be defective, Warrantor will ship a replacement part, directly to your home, without charge. If a repair or replacement part is unavailable, Warrantor may refund the original purchase price. After the first year, labor necessary to maintain this product is not covered by the product warranty.

If you have questions regarding a warranted product, need assistance with installation or troubleshooting, wish to order a part or report a warranty issue, we are just a phone call away. SIMPLY DIAL 1-800-693-1138 for assistance.

This water treatment system is manufactured by  
Water Channel Partners, 1890 Woodlane Drive, Woodbury, MN 55125

#### **General Provisions**

The above warranties are effective provided the water treatment system is operated at water pressures not exceeding 100 psi (7.0 kg/cm<sup>2</sup>), and at water temperatures not exceeding 100°F (38°C); provided further that the water treatment system is not subject to abuse, misuse, alteration, neglect, freezing, accident or negligence; and provided further that the water treatment system is not damaged as the result of any force of nature such as, but not limited to, flood, hurricane, tornado or earthquake.

The limited warranty does not cover damage due to: (a) transportation, (b) storage, (c) improper use, (d) failure to follow the product instructions or to perform any preventive maintenance, (e) modifications, (f) unauthorized repair, (g) normal wear and tear, or (h) external causes such as accidents, abuse, or other actions or events beyond Warrantor's reasonable control. Use of aftermarket, used, or non-manufacturer provided parts will void all warranties. Warranty does not cover failures due to improper product installation. Warrantor is excused if failure to perform its warranty obligations is the result of strikes, government regulation, materials shortages, or other circumstances beyond its control.

THERE ARE NO WARRANTIES ON THE WATER TREATMENT SYSTEM BEYOND THOSE SPECIFICALLY DESCRIBED ABOVE. ALL IMPLIED WARRANTIES, INCLUDING ANY IMPLIED WARRANTY OF MERCHANTABILITY OR OF FITNESS FOR A PARTICULAR PURPOSE, ARE DISCLAIMED TO THE EXTENT THEY MIGHT EXTEND BEYOND THE ABOVE PERIODS. THE SOLE OBLIGATION OF WARRANTOR UNDER THESE WARRANTIES IS TO REPLACE OR REPAIR THE COMPONENT OR PART WHICH PROVES TO BE DEFECTIVE WITHIN THE SPECIFIED TIME PERIOD, AND WARRANTOR IS NOT LIABLE FOR CONSEQUENTIAL OR INCIDENTAL DAMAGES. NO DEALER, AGENT, REPRESENTATIVE, OR OTHER PERSON IS AUTHORIZED TO EXTEND OR EXPAND THE WARRANTIES EXPRESSLY DESCRIBED ABOVE.

Some states do not allow the exclusion or limitation of incidental or consequential damages, so the above limitation or exclusion may not apply to you. This warranty gives you specific legal rights, and you may have other rights which vary from state to state. This warranty applies to consumer-owned installations only.